

E-Z LOK Products are available from MARYLAND METRICS

P.O. Box 261 MD 21117 USA

phones: (410)358-3130 (800)638-1830 faxes: (410)358-3142 (800)872-9329

web: <http://mdmetric.com> email: sales@mdmetric.com

E-Z LOK

THREADED INSERTS



FOR STRONG THREADS IN:

METAL

WOOD

PLASTIC



E-Z LOK Products are available from MARYLAND METRICS

P.O. Box 261 MD 21117 USA

phones: (410)358-3130 (800)638-1830 faxes: (410)358-3142 (800)872-9329 web: <http://mdmetric.com> email: sales@mdmetric.com

**THREADED INSERTS
FOR METAL**

INSTALLATION	3
CARBON STEEL	4
CARBON STEEL (METRIC)	5
STAINLESS (UNC/UNF/METRIC) ..	6
PREPACKAGED THREADED INSERT KITS	7

**ULTRASONIC INSERTS
FOR THERMOPLASTICS**

TAPERED	8
STRAIGHT	9

PRESS INSERTS FOR THERMOSET PLASTICS **10**

KNIFE THREAD INSERTS FOR HARD WOOD **11**

HEX DRIVE INSERTS FOR SOFT WOOD **11**

INSERTS FOR SOFT WOOD AND PLASTIC **12**

STRONG THREADS MADE EASY

ALL EZ LOK INSERTS INSTALL WITH STANDARD TOOLS
NO SPECIAL DRILLS... NO SPECIAL TAPS... NO SPECIAL INSTALLATION TOOLS

E-Z LOK external threads are standard size and pitch to permit use of standard drills and taps. No special tap sizes or installation tools are required.

E-Z LOK inserts will not back out or vibrate loose. Immediately upon installation, microencapsulated adhesive begins to set and the newly installed insert can be fastened to within minutes. In addition, the adhesive seals against liquids and gases to pressures of 6,000 psi, and bonds to virtually all metals.

EASY REMOVAL Use a standard screw and bolt extractor to back out a damaged insert and then replace it with a new insert. Removal is simply a matter of overcoming the resistance to torque-out which has been produced by the thread locking material.



Power drive tools are available for high volume installation... See insert tables for catalog numbers and sizes.



WHAT'S THE DIFFERENCE?



Q: What's the difference between E-Z LOK and coil threaded inserts?

A: There are two primary differences: design and installation.

Design

As the name implies, coil inserts are steel wire coiled in a spring-like design. E-Z LOK threaded inserts are screw machined out of solid steel.

Installation

To install a coil insert, you must have a special drill, special tap, and special installation tool. If a tap breaks or the installation tool is misplaced, the coil inserts can't be installed until a new tap or installation tool is purchased. E-Z LOK threaded inserts have standard size/pitch threads so they can be installed using standard tools probably already in your toolbox. For example, to install an E-Z LOK 329-5 (which has a 1/2-13 external thread), you would simply drill the hole with a standard 27/64 drill and then tap the hole with a standard 1/2-13 tap. Once that's done, the insert is threaded into the hole like an ordinary fastener using a screwdriver, bolt and jam nut, or an E-Z LOK drive tool.

COARSE THREAD SIZES

EZ-LOK Part No.	Internal Thread	External Thread	Length in.	Tap Drill Size	Tap Size	Minimum Full Thread Depth	Drive Tool Catalog No.
329-004	4-40	10-32	.250	5/32	10-32	9/32	—
329-006	6-32	1/4-20	.280	7	1/4-20	11/32	500-006
329-008	8-32	5/16-18	.290	F	5/16-18	7/16	500-1
329-3	10-24	3/8-16	.406	5/16	3/8-16	15/32	500-2
329-4	1/4-20	7/16-14	.437	23/64	7/16-14	1/2	500-3
329-5	5/16-18	1/2-13	.484	27/64	1/2-13	9/16	500-4
329-6	3/8-16	9/16-12	.515	31/64	9/16-12	19/32	500-5
329-7	7/16-14	5/8-11	.656	17/32	5/8-11	23/32	500-6
329-8	1/2-13	3/4-10	.656	21/32	3/4-10	3/4	500-7
329-801	1/2-13	3/4-10	1.000	21/32	3/4-10	3/4	500-7
329-9	9/16-12	3/4-10	.656	21/32	3/4-10	3/4	500-7
329-10	5/8-11	7/8-9	.687	49/64	7/8-9	13/16	500-8
329-1018	5/8-11	7/8-9	1.125	49/64	7/8-9	1-1/4	500-8
329-12	3/4-10	1-8	.781	7/8	1-8	7/8	500-9
329-14	7/8-9	1-1/4-7	1.125	1-7/64	1-1/4-7	1-1/4	—
329-16	1-8	1-3/8-12	1.250	1-9/32	1-3/8-12	1-3/8	—

FINE THREAD SIZES

EZ-LOK Part No.	Internal Thread	External Thread	Length in.	Tap Drill Size	Tap Size	Minimum Full Thread Depth	Drive Tool Catalog No.
329-332	10-32	3/8-16	.406	5/16	3/8-16	15/32	500-2
329-428	1/4-28	7/16-14	.437	23/64	7/16-14	1/2	500-3
329-524	5/16-24	1/2-13	.484	27/64	1/2-13	9/16	500-4
329-624	3/8-24	9/16-12	.515	31/64	9/16-12	19/32	500-5
329-720	7/16-20	5/8-11	.656	17/32	5/8-11	23/32	500-6
329-820	1/2-20	3/4-10	.656	21/32	3/4-10	3/4	500-7
329-918	9/16-18	3/4-10	.656	21/32	3/4-10	3/4	500-7
329-10F	5/8-18	7/8-9	.687	49/64	7/8-9	13/16	500-8
329-1216	3/4-16	1-8	.781	7/8	1-8	7/8	500-9
329-1414	7/8-14	1-1/4-7	1.125	1-7/64	1-1/4-7	1-1/4	—
329-1614	1-14	1-3/8-12	1.250	1-9/32	1-3/8-12	1-3/8	—

THIN WALL — COARSE THREAD SIZES

EZ-LOK Part No.	Internal Thread	External Thread	Length in.	Tap Drill Size	Tap Size	Minimum Full Thread Depth	Drive Tool Catalog No.
319-3	10-24	5/16-18	.312	I	5/16-18	.375	500-2
319-4	1/4-20	3/8-16	.375	Q	3/8-16	.437	500-3
319-5	5/16-18	7/16-14	.437	X	7/16-14	.500	500-4
319-6	3/8-16	1/2-13	.500	29/64	1/2-13	.560	500-5
319-7	7/16-14	9/16-12	.560	33/64	9/16-12	.620	500-6
319-8	1/2-13	5/8-11	.620	37/64	5/8-11	.680	500-7

THIN WALL — FINE THREAD SIZES

EZ-LOK Part No.	Internal Thread	External Thread	Length in.	Tap Drill Size	Tap Size	Minimum Full Thread Depth	Drive Tool Catalog No.
319-332	10-32	5/16-18	.312	I	5/16-18	.375	500-2
319-428	1/4-28	3/8-16	.375	Q	3/8-16	.437	500-3
319-524	5/16-24	7/16-14	.437	X	7/16-14	.500	500-4
319-624	3/8-24	1/2-13	.500	29/64	1/2-13	.560	500-5
319-720	7/16-20	9/16-12	.560	33/64	9/16-12	.620	500-6
319-820	1/2-20	5/8-11	.620	37/64	5/8-11	.680	500-7

EXTRA HEAVY WALL — COARSE THREAD SIZES

EZ-LOK Part No.	Internal Thread	External Thread	Length in.	Tap Drill Size	Tap Size	Minimum Full Thread Depth	Drive Tool Catalog No.
335-4	1/4-20	1/2-13	.484	27/64	1/2-13	9/16	500-3
335-5	5/16-18	9/16-12	.515	31/64	9/16-12	19/32	500-4
335-6	3/8-16	5/8-11	.656	17/32	5/8-11	23/32	500-5
335-8	1/2-13	7/8-9	.687	49/64	7/8-9	13/16	—
335-10	5/8-11	1-8	.781	7/8	1-8	7/8	—

METRIC THREAD SIZES — METRIC INTERNAL/METRIC EXTERNAL

EZ-LOK Part No.	Internal Thread	External Thread	Length	Tap Drill Size	Tap Size	Minimum Full Thread Depth	Drive Tool Catalog No.
450-3	M3-0.5	M6-1.0	6.5mm	5.1mm	M6-1.0	7.8mm	—
450-4	M4-0.7	M8-1.25	7.5mm	6.9mm	M8-1.25	9.0mm	500-1
450-5	M5-0.8	M8-1.25	7.5mm	6.9mm	M8-1.25	9.0mm	500-1
450-6	M6-1.0	M10-1.5	10.5mm	8.6mm	M10-1.5	12.0mm	500-3
450-8	M8-1.25	M12-1.75	12.5mm	10.4mm	M12-1.75	14.5mm	500-4
450-10	M10-1.5	M16-2.0	17.0mm	14.0mm	M16-2.0	19.0mm	500-5
450-12	M12-1.75	M16-2.0	17.0mm	14.0mm	M16-2.0	19.0mm	500-6
450-16	M16-2.0	M24-3.0	20.0mm	21.0mm	M24-3.0	24.0mm	500-8
450-20	M20-2.5	M36-4.0	30.0mm	33.0mm	M36-4.0	35.0mm	—

METRIC THREAD SIZES — U.S. INTERNAL/METRIC EXTERNAL

EZ-LOK Part No.	Internal Thread	External Thread	Length	Tap Drill Size	Tap Size	Minimum Full Thread Depth	Drive Tool Catalog No.
550-006	6-32	M6-1.0	6.5 mm	5.1mm	M6-1.0	7.8mm	—
550-008	8-32	M8-1.25	7.5 mm	6.9mm	M8-1.25	9.0mm	500-1
550-1024	10-24	M8-1.25	7.5 mm	6.9mm	M8-1.25	12.0mm	500-2
550-1032	10-32	M8-1.25	7.5 mm	6.9mm	M8-1.25	12.0mm	500-2
550-1420	1/4-20	M10-1.5	10.5 mm	8.6mm	M10-1.5	14.5mm	500-3
550-5	5/16-18	M12-1.75	12.5 mm	10.4mm	M12-1.75	14.5mm	500-4
550-6	3/8-16	M16-2.0	17.0 mm	14.0mm	M16-2.0	19.0mm	500-5
550-8	1/2-13	M16-2.0	17.0 mm	14.0mm	M16-2.0	19.0mm	500-7

METRIC THREAD SIZES — METRIC INTERNAL/U.S. EXTERNAL

EZ-LOK Part No.	Internal Thread	External Thread	Length	Tap Drill Size	Tap Size	Minimum Full Thread Depth	Drive Tool Catalog No.
650-6	M6-1.0	3/8-16	.406	5/16	3/8-16	15/32	500-3
650-8	M8-1.25	1/2-13	.484	27/64	1/2-13	9/16	500-4
65010	M10-1.50	9/16-12	.515	31/64	9/16-12	19/32	500-5
650-10F	M10-1.25	9/16-12	.515	31/64	9/16-12	19/32	500-5
650-12	M12-1.75	3/4-10	.656	21/32	3/4-10	3/4	500-6
650-14	M14-2.0	7/8-9	.687	49/64	7/8-9	13/16	500-7
650-16	M16-2.0	1-8	.781	7/8	1-8	7-8	500-8

AUTOMOTIVE DESIGNS

EZ-LOK Part No.	Internal Thread	External Thread	Length	Tap Drill Size	Tap Size	
SPARK PLUG SIZES						
329-1008	M10-1.0	9/16-18	.453	33/64	9/16-18	
329-1208	M12-1.25	5/8-18	.453	37/64	5/8-18	
329-1212	M12-1.25	5/8-18	.703	37/64	5/8-18	
750-14	M14-1.25	M18-1.5	11.5mm	16.5mm	M18-1.5	
329-1406	M14-1.25	3/4-16	.328	11/16	3/4-16	
329-1408	M14-1.25	3/4-16	.453	11/16	3/4-16	
329-1412	M14-1.25	3/4-16	.703	11/16	3/4-16	
329-1808	M18-1.5	1-12	.453	59/64	1-12	
VW CASE SAVERS						
330-10 (Open)	M10-1.50	9/16-12	1.000	31/64	9/16-12	
330-11 (Closed)	M10-1.50	9/16-12	1.000	31/64	9/16-12	

COARSE THREAD SIZES IN STAINLESS STEEL

EZ-LOK Part No.	Internal Thread	External Thread	Length in.	Tap Drill Size	Tap Size	Minimum Full Thread Depth	Drive Tool Catalog No.
303-004	4-40	10-32	.250	5/32	10-32	9/32	—
303-006	6-32	1/4-20	.280	7	1/4-20	11/32	—
303-008	8-32	5/16-18	.290	F	5/16-18	7/16	500-1
303-3	10-24	3/8-16	.406	5/16	3/8-16	15/32	500-2
303-4	1/4-20	7/16-14	.437	23/64	7/16-14	1/2	500-3
303-5	5/16-18	1/2-13	.484	27/64	1/2-13	9/16	500-4
303-6	3/8-16	9/16-12	.515	31/64	9/16-12	19/32	500-5
303-7	7/16-14	5/8-11	.656	17/32	5/8-11	23/32	500-6
303-8	1/2-13	3/4-10	.656	21/32	3/4-10	3/4	500-7
303-10	5/8-11	7/8-9	.687	49/64	7/8-9	13/16	500-8
303-12	3/4-10	1-8	.781	7/8	1-8	7/8	500-9

FINE THREAD SIZES IN STAINLESS STEEL

EZ-LOK Part No.	Internal Thread	External Thread	Length in.	Tap Drill Size	Tap Size	Minimum Full Thread Depth	Drive Tool Catalog No.
303-332	10-32	3/8-16	.406	5/16	3/8-16	15/32	500-2
303-428	1/4-28	7/16-14	.437	23/64	7/16-14	1/2	500-3
303-524	5/16-24	1/2-13	.484	27/64	1/2-13	9/16	500-4
303-624	3/8-24	9/16-12	.515	31/64	9/16-12	19/32	500-5
303-720	7/16-20	5/8-11	.656	17/32	5/8-11	23/32	500-6
303-820	1/2-20	3/4-10	.656	21/32	3/4-10	3/4	500-7

METRIC THREAD SIZES IN STAINLESS STEEL — METRIC INTERNAL/METRIC EXTERNAL

EZ-LOK Part No.	Internal Thread	External Thread	Length	Tap Drill Size	Tap Size	Minimum Full Thread Depth	Drive Tool Catalog No.
453-3	M3-0.5	M6-1.0	6.5mm	5.1mm	M6-1.0	7.8mm	—
453-4	M4-0.7	M8-1.25	7.5mm	6.9mm	M8-1.25	9.0mm	500-1
453-5	M5-0.8	M8-1.25	7.5mm	6.9mm	M8-1.25	9.0mm	500-1
453-6	M6-1.0	M10-1.5	10.5mm	8.6mm	M10-1.5	12.0mm	500-3
453-8	M8-1.25	M12-1.75	12.5mm	10.4mm	M12-1.75	14.5mm	500-4
453-10	M10-1.5	M16-2.0	17.0mm	14.0mm	M16-2.0	19.0mm	500-5
453-12	M12-1.75	M16-2.0	17.0mm	14.0mm	M16-2.0	19.0mm	500-6
453-16	M16-2.0	M24-3.0	20.0mm	21.0mm	M24-3.0	24.0mm	500-8

METRIC THREAD SIZES IN STAINLESS STEEL — METRIC INTERNAL/U.S. EXTERNAL

EZ-LOK Part No.	Internal Thread	External Thread	Length	Tap Drill Size	Tap Size	Minimum Full Thread Depth	Drive Tool Catalog No.
653-6	M6-1.0	3/8-16	.406	5/16	3/8-16	15/32	500-3
653-8	M8-1.25	1/2-13	.484	27/64	1/2-13	9/16	500-4
653-10	M10-1.50	9/16-12	.515	31/64	9/16-12	19/32	500-5
653-10F	M10-1.25	9/16-12	.515	31/64	9/16-12	19/32	500-5
653-12	M12-1.75	3/4-10	.656	21/32	3/4-10	3/4	500-6
653-14	M14-2.0	7/8-9	.687	49/64	7/8-9	13/16	500-7
653-16	M16-2.0	1-8	.781	7/8	1-8	7/8	500-8

INSTALLATION VIDEO

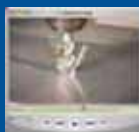

VISIT OUR WEBSITE AT WWW.EZLOK.COM TO VIEW A VIDEO DEMONSTRATING THE EASY 1-2-3 INSTALLATION OF E-Z LOK THREADED INSERTS



Prepackaged kits containing a range of sizes are available.

Note: Because E-Z LOK inserts install with standard tools, our kits contain only inserts. Drills and taps are not included.

CARBON STEEL THREAD INSERTS FOR METAL

Kit Type	Kit Number	Quantity of Inserts	Insert Part Number	Internal Thread	External Thread
Coarse Thread #10 to 7/16"	EZ C107	10	329-3	10-24	3/8-16
		10	329-4	1/4-20	7/16-14
		10	329-5	5/16-18	1/2-13
		10	329-6	3/8-16	9/16-12
		8	329-7	7/16-14	5/8-11
Coarse Thread #10 to 1/2"	EZ C108	10	329-3	10-24	3/8-16
		10	329-4	1/4-20	7/16-14
		10	329-5	5/16-18	1/2-13
		10	329-6	3/8-16	9/16-12
		6	329-8	1/2-13	3/4-10
Coarse Thread 1/2" to 1"	EZ C816	6	329-8	1/2-13	3/4-10
		7	329-10	5/8-11	7/8-9
		7	329-12	3/4-10	1-8
		2	329-16	1-8	1-3/8-12
Fine Thread #10 to 7/16"	EZ F107	10	329-332	10-32	3/8-16
		10	329-428	1/4-28	7/16-14
		10	329-524	5/16-24	1/2-13
		8	329-720	7/16-20	5/8-11
Fine Thread #10 to 1/2"	EZ F108	10	329-332	10-32	3/8-16
		10	329-428	1/4-28	7/16-14
		10	329-524	5/16-24	1/2-13
		10	329-624	3/8-24	9/16-12
		6	329-820	1/2-20	3/4-10
Fine Thread 1/2" to 1"	EZ F816	6	329-820	1/2-20	3/4-10
		7	329-10F	5/8-18	7/8-9
		7	329-1216	3/4-16	1-8
		2	329-1614	1-14	1-3/8-12

CARBON STEEL THREAD INSERTS FOR METAL — METRIC

Kit Type	Kit Number	Quantity of Inserts	Insert Part Number	Internal Thread	External Thread
M3-0.5 to M8-1.25	EZ M100	10	450-3	M3-0.5	M6-1.0
		10	450-4	M4-0.7	M8-1.25
		10	450-5	M5-0.8	M8-1.25
		10	450-6	M6-1.0	M10-1.5
		10	450-8	M8-1.25	M12-1.75
M8-1.25 to M16-2.0	EZ M200	10	450-8	M8-1.25	M12-1.75
		10	450-10	M10-1.5	M16-2.0
		8	450-12	M12-1.75	M16-2.0
		5	450-16	M16-2.0	M24-3.0
Coarse Thread #10 to 1/2"	EZ M508	10	550-3	10-24	M10-1.5
		10	550-4	1/4-20	M12-1.75
		10	550-5	5/16-18	M12-1.75
		10	550-6	3/8-16	M16-2.0
		6	550-8	1/2-13	M16-2.0
Metric Thread M6 to M12	EZ M612	10	650-6	M6-1.0	3/8-16
		10	650-8	M8-1.25	1/2-13
		10	650-10	M10-1.5	9/16-12
		6	650-12	M12-1.75	3/4-10

STAINLESS STEEL THREAD INSERTS FOR METAL

Kit Type	Kit Number	Quantity of Inserts	Insert Part Number	Internal Thread	External Thread
Coarse Thread 303 Stainless #10 to 1/2"	EZ C303	10	303-3	10-24	3/8-16
		10	303-4	1/4-20	7/16-14
		10	303-5	5/16-18	1/2-13
		10	303-6	3/8-16	9/16-12
		6	303-8	1/2-13	3/4-10
Fine Thread 303 Stainless #10 to 1/2"	EZ F303	10	303-332	10-32	3/8-16
		10	303-428	1/4-28	7/16-14
		10	303-524	5/16-24	1/2-13
		10	303-624	3/8-24	9/16-12
		6	303-820	1/2-20	3/4-10
M3-0.5 to M8-1.25	EZ M103	10	453-3	M3-0.5	M6-1.0
		10	453-4	M4-0.7	M8-1.25
		10	453-5	M5-0.8	M8-1.25
		10	453-6	M6-1.0	M10-1.5
		10	453-8	M8-1.25	M12-1.75
M8-1.25 to M16-2.0	EZ M203	10	453-8	M8-1.25	M12-1.75
		10	453-10	M10-1.5	M16-2.0
		8	453-12	M12-1.75	M16-2.0
		5	453-16	M16-2.0	M24-3.0
Metric Thread M6 to M12	EZ M613	10	653-6	M6-1.0	3/8-16
		10	653-8	M8-1.25	1/2-13
		10	653-10	M10-1.5	9/16-12
		6	653-12	M12-1.75	3/4-10

ULTRASONIC INSERTS—TAPERED

DESIGNED FOR USE IN THERMOPLASTICS

- TAPERED DESIGN REDUCES INSTALLATION TIME
- INSTALL ULTRASONICALLY OR WITH HEAT DRIVER
- SUPERIOR TORQUE/PULL OUT RESISTANCE
- UNC AND METRIC THREADS
- SINGLE AND DOUBLE VANE



TAPERED SINGLE VANE

Part Number.	Internal Thread	Overall Length (L)	Insert Diameter (W)	Pilot Diameter (N)	Rec. Hole Size* (D)	Rec. Hole Size* (S)	Minimum Wall Thickness
TH-002-SV	2-56	.115	.136	.122	.123	.118	.080
TH-004-SV	4-40	.135	.172	.157	.159	.153	.093
TH-006-SV	6-32	.150	.220	.203	.206	.199	.116
TH-008-SV	8-32	.185	.250	.230	.234	.226	.133
TH-124-SV	10-24	.225	.296	.272	.277	.267	.159
TH-132-SV	10-32	.225	.296	.272	.277	.267	.159
TH-420-SV	1/4-20	.300	.375	.354	.363	.349	.194
TH-428-SV	1/4-28	.300	.375	.354	.363	.349	.194
TH-518-SV	5/16-18	.335	.469	.439	.448	.431	.245
TH-316-SV	3/8-16	.375	.563	.530	.540	.523	.293
TH-324-SV	3/8-24	.375	.563	.530	.540	.523	.293
TH-M25-SV	M2.5-0.4	.135	.172	.157	.159	.153	.093
TH-M30-SV	M3-0.5	.150	.220	.203	.206	.199	.116
TH-M40-SV	M4-0.7	.185	.250	.230	.234	.226	.133
TH-M50-SV	M5-0.8	.265	.328	.308	.315	.303	.171
TH-M60-SV	M6-1.0	.300	.375	.354	.363	.349	.194

* Hole size requirements may vary depending on a number of factors, including material and tools. We recommend that you test your particular application before ordering. We gladly supply free samples.

TAPERED DOUBLE VANE

Part Number.	Internal Thread	Overall Length (L)	Insert Diameter (W)	Pilot Diameter (N)	Rec. Hole Size* (D)	Rec. Hole Size* (S)	Minimum Wall Thickness
DV-002-TH	2-56	.188	.136	.115	.123	.107	.080
DV-004-TH	4-40	.219	.172	.144	.159	.141	.093
DV-006-TH	6-32	.250	.220	.190	.206	.185	.116
DV-008-TH	8-32	.312	.250	.212	.234	.208	.133
DV-124-TH	10-24	.375	.297	.251	.277	.246	.159
DV-132-TH	10-32	.375	.297	.251	.277	.246	.159
DV-420-TH	1/4-20	.500	.375	.332	.363	.321	.194
DV-428-TH	1/4-28	.500	.375	.332	.363	.321	.194
DV-518-TH	5/16-18	.562	.469	.406	.448	.401	.245
DV-316-TH	3/8-16	.625	.563	.493	.540	.488	.293
DV-M25-TH	M2.5-0.4	.219	.172	.144	.159	.141	.093
DV-M30-TH	M3-0.5	.250	.220	.190	.206	.185	.116
DV-M40-TH	M4-0.7	.312	.250	.212	.234	.208	.133
DV-M50-TH	M5-0.8	.438	.328	.283	.315	.278	.171
DV-M60-TH	M6-1.0	.500	.375	.332	.363	.321	.194

* Hole size requirements may vary depending on a number of factors, including material and tools. We recommend that you test your particular application before ordering. We gladly supply free samples.

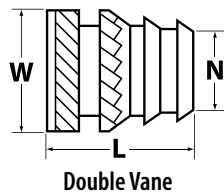
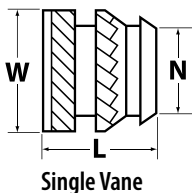

Hole depth should be a minimum of .030" greater than the length of the insert in blind holes.

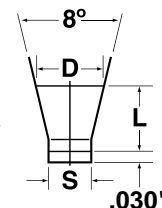

ULTRASONIC INSERTS—STRAIGHT

DESIGNED FOR USE IN THERMOPLASTICS

- STRAIGHT DESIGN PERMITS THINNER BOSS WALLS
- INSTALL ULTRASONICALLY OR WITH HEAT DRIVER
- SUPERIOR TORQUE/PULL OUT RESISTANCE
- FLUSH AND FLANGED DESIGNS



STRAIGHT FLUSH

Part Number.	Internal Thread	Overall Length (L)	Insert Diameter (W)	Head Diameter (H)	Pilot Diameter (N)	Rec. Hole Size*	Minimum Wall Thickness
HI-002-WH	2-56	.157	.141	N/A	.123	.126	.051
HI-004-WH	4-40	.226	.181	N/A	.154	.157	.063
HI-006-WH	6-32	.281	.214	N/A	.185	.189	.071
HI-008-WH	8-32	.321	.248	N/A	.218	.220	.083
HI-124-WH	10-24	.375	.278	N/A	.249	.252	.102
HI-132-WH	10-32	.375	.278	N/A	.249	.252	.102
HI-420-WH	1/4-20	.500	.341	N/A	.312	.315	.130
HI-428-WH	1/4-28	.500	.341	N/A	.312	.315	.130
HI-518-WH	5/16-18	.500	.403	N/A	.374	.378	.177
HI-524-WH	5/16-24	.500	.403	N/A	.374	.378	.177
HI-316-WH	3/8-16	.500	.494	N/A	.465	.469	.236
HI-324-WH	3/8-24	.500	.494	N/A	.465	.469	.236

* Hole size requirements may vary depending on a number of factors, including material and tools. We recommend that you test your particular application before ordering. We gladly supply free samples. "

STRAIGHT FLANGED

Part Number.	Internal Thread	Overall Length (L+T)	Insert Diameter (W)	Head Diameter (H)	Pilot Diameter (N)	Rec. Hole Size*	Minimum Wall Thickness
FL-256-HI	2-56	.178	.141	.187	.123	.126	.051
FL-440-HI	4-40	.250	.181	.218	.154	.157	.063
FL-632-HI	6-32	.311	.214	.250	.185	.189	.071
FL-832-HI	8-32	.357	.248	.281	.218	.220	.083
FL-124-HI	10-24	.418	.278	.312	.249	.252	.102
FL-132-HI	10-32	.418	.278	.312	.249	.252	.102
FL-420-HI	1/4-20	.553	.341	.375	.312	.315	.130
FL-428-HI	1/4-28	.553	.341	.375	.312	.315	.130
FL-518-HI	5/16-18	.553	.403	.437	.374	.378	.177
FL316-HI	3/8-16	.563	.494	.551	.465	.469	.236

* Hole size requirements may vary depending on a number of factors, including material and tools. We recommend that you test your particular application before ordering. We gladly supply free samples.

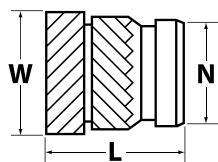

Flush

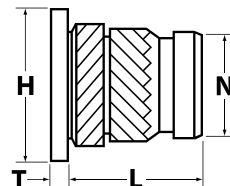

Flanged

FOR CORED OR DRILLED HOLES IN PLASTIC

Diamond-knurled press inserts are designed to replace molded-in inserts and threads in thermoset plastics.



- INSTALL COLD
- SHARPLY REDUCE THE COST OF MOLDINGS
- CUT REJECT WASTE CAUSED BY MISALIGNED AND FAULTY INSERTS
- ELIMINATE THE NEED TO "CHASE" THREADS AFTER MOLDING
- INSTALL PROPERLY WITHOUT A PRECISE HOLE DEPTH

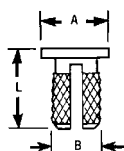
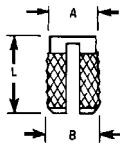
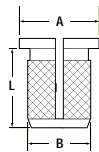
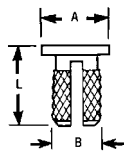
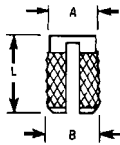

* Hole size requirements may vary depending on a number of factors, including material and tools. We recommend that you test your particular application before ordering. We gladly supply free samples.

BRASS — FLUSH

EZ-LOK Part No.	Internal Thread	A ±.010"	B ±.010"	L ±.010"	Starting Hole Size*
240-000-BR	0-80	.094	.104	.125	.094 (3/32)
240-002-BR	2-56	.125	.135	.156	.125 (1/8)
240-004-BR	4-40	.156	.166	.188	.156 (5/32)
240-006-BR	6-32	.187	.199	.250	.188 (3/16)
240-008-BR.250	8-32	.218	.230	.250	.219 (7/32)
240-008-BR	8-32	.218	.230	.313	.219 (7/32)
240-332-BR.250	10-32	.250	.262	.250	.250 (1/4)
240-332-BR	10-32	.250	.262	.375	.250 (1/4)
240-3-BR	10-24	.250	.262	.375	.250 (1/4)
240-4-BR	1/4-20	.312	.326	.500	.313 (5/16)
240-5-BR	5/16-18	.375	.389	.563	.375 (3/8)
240-6-BR	3/8-16	.437	.451	.625	.438 (7/16)
240-M3-BR	M3-0.5	.156	.166	.188	.156 (5/32)
240-M3.5-BR	M3.5-0.6	.187	.199	.250	.188 (3/16)
240-M4-BR	M4-0.7	.218	.230	.313	.219 (7/32)
240-M5-BR	M5-0.8	.250	.262	.375	.250 (1/4)
240-M6-BR	M6-1.0	.312	.326	.500	.313 (5/16)

BRASS — FLANGED

EZ-LOK Part No.	Internal Thread	A ±.010"	B ±.010"	L ±.010"	Starting Hole Size*
260-002-BR	2-56	.187	.135	.156	.125 (1/8)
260-004-BR	4-40	.218	.166	.188	.156 (5/32)
260-006-BR	6-32	.249	.199	.250	.188 (3/16)
260-008-BR	8-32	.280	.230	.313	.219 (7/32)
260-332-BR	10-32	.312	.262	.375	.250 (1/4)
260-4-BR	1/4-20	.375	.326	.500	.313 (5/16)
260-5-BR	5/16-18	.437	.389	.563	.375 (3/8)
260-6-BR	3/8-16	.500	.451	.625	.438 (7/16)

BRASS — FLANGED — REVERSED SLOT

EZ-LOK Part No.	Internal Thread	A ±.010"	B ±.010"	L ±.010"	Starting Hole Size*
260-002-RS	2-56	.187	.135	.156	.125 (1/8)
260-004-RS	4-40	.218	.166	.188	.156 (5/32)
260-006-RS	6-32	.249	.199	.250	.188 (3/16)
260-008-RS	8-32	.280	.230	.313	.219 (7/32)
260-332-RS	10-32	.312	.262	.375	.250 (1/4)
260-4-RS	1/4-20	.375	.326	.500	.313 (5/16)

STAINLESS STEEL — FLUSH

EZ-LOK Part No.	Internal Thread	A ±.010"	B ±.010"	L ±.010"	Starting Hole Size*
240-002-CR	2-56	.125	.135	.156	.125 (1/8)
240-004-CR	4-40	.156	.166	.188	.156 (5/32)
240-006-CR	6-32	.187	.199	.250	.188 (3/16)
240-008-CR	8-32	.218	.230	.313	.219 (7/32)
240-332-CR	10-32	.250	.262	.375	.250 (1/4)
240-4-CR	1/4-20	.312	.326	.500	.313 (5/16)
240-5-CR	5/16-18	.375	.389	.563	.375 (3/8)
240-6-CR	3/8-16	.437	.451	.625	.438 (7/16)

STAINLESS STEEL — FLANGED

EZ-LOK Part No.	Internal Thread	A ±.010"	B ±.010"	L ±.010"	Starting Hole Size*
260-002-CR	2-56	.187	.135	.156	.125 (1/8)
260-004-CR	4-40	.218	.166	.188	.156 (5/32)
260-006-CR	6-32	.249	.199	.250	.188 (3/16)
260-008-CR	8-32	.280	.230	.313	.219 (7/32)
260-332-CR	10-32	.312	.262	.375	.250 (1/4)
260-4-CR	1/4-20	.375	.326	.500	.313 (5/16)



External knife threads provide superior holding power in hard and soft woods, particle board and all wood products. Use wherever field assembly or disassembly could lead to thread erosion or stripping. The long pilot ensures straight driving into a drilled hole. Install with screwdriver, bolt and nut, tapping head, or E-Z LOK driving tool.



BRASS KNIFE THREAD INSERTS — FOR WOOD

EZ-LOK Part No.	Internal Thread	Length	Major Diameter External Thread	Hole* Size	Drive Tool Catalog Number
400-004	4-40	.375	.350	1/4"	—
400-006	6-32	.375	.350	1/4"	500-006
400-008	8-32	.375	.350	1/4"	500-1
400-3	10-24	.500	.453	3/8"	500-2
400-332	10-32	.500	.453	3/8"	500-2
400-4	1/4-20	.500	.453	3/8"	500-3
400-428	1/4-28	.500	.453	3/8"	500-3
400-5	5/16-18	.625	.600	1/2"	500-4
400-524	5/16-24	.625	.600	1/2"	500-4
400-6	3/8-16	.625	.600	1/2"	500-5
400-624	3/8-24	.625	.600	1/2"	500-5
400-M3	M3-0.5	.375	.350	1/4"	500-006
400-M4	M4-0.7	.375	.350	1/4"	500-1
400-M5	M5-0.8	.500	.453	3/8"	500-2
400-M6	M6-1.0	.500	.453	3/8"	500-3
400-M8	M8-1.25	.625	.600	1/2"	500-5

STAINLESS STEEL KNIFE THREAD INSERTS — FOR WOOD

EZ-LOK Part No.	Internal Thread	Length	Major Diameter External Thread	Hole* Size	Drive Tool Catalog Number
400-008-CR	8-32	.375	.350	1/4"	500-1
400-3-CR	10-24	.500	.453	3/8"	500-2
400-4-CR	1/4-20	.500	.453	3/8"	500-3

*Hole size requirements may vary depending on material and tools. We recommend that you test before ordering. We gladly supply free samples.



DIE CAST ZINC ALLOY HEXDRIVE THREAD INSERTS — FOR WOOD

EZ-LOK Part No.	Design	Internal Thread	Length	Hole* Size	Hex Dimensions	Drive Tool. Catalog Number
800832-10	Flush	8-32	10mm	6mm	M4	8500
801024-13	Flush	10-24	13mm	7mm	M5	8600
801032-13	Flush	10-32	13mm	7mm	M5	8600
801420-13	Flush	1/4-20	13mm	9mm	M6	9000
801420-20	Flush	1/4-20	20mm	9mm	M6	9000
851618-20	Flush	5/16-18	20mm	11mm	M8	9100
851618-25	Flush	5/16-18	25mm	11mm	M8	9100
800610-13	Flush	M6-1.0	13mm	9mm	M6	9000
800610-20	Flush	M6-1.0	20mm	9mm	M6	9000
808125-13	Flush	M8-1.25	13mm	11mm	M8	9100
808125-20	Flush	M8-1.25	20mm	11mm	M8	9100
900832-10	Flanged	8-32	10mm	6mm	M4	8500
901024-11	Flanged	10-24	11mm	7mm	M5	8600
901024-20	Flanged	10-24	20mm	7mm	M5	8600
901032-11	Flanged	10-32	11mm	7mm	M5	8600
901032-13	Flanged	10-32	13mm	7mm	M5	8600
901032-20	Flanged	10-32	20mm	7mm	M5	8600
901420-13	Flanged	1/4-20	13mm	9mm	M6	9000
901420-20	Flanged	1/4-20	20mm	9mm	M6	9000
901420-25	Flanged	1/4-20	25mm	9mm	M6	9000
951618-13	Flanged	5/16-18	13mm	11mm	M8	9100
951618-25	Flanged	5/16-18	25mm	11mm	M8	9100
903816-13	Flanged	3/8-16	13mm	12mm	M10	9200
903816-25	Flanged	3/8-16	25mm	12mm	M10	9200
900610-13	Flanged	M6-1.0	13mm	9mm	M6	9000
900610-20	Flanged	M6-1.0	20mm	9mm	M6	9000
908125-13	Flanged	M8-1.25	13mm	11mm	M8	9100
908125-20	Flanged	M8-1.25	20mm	11mm	M8	9100

An inexpensive insert for use in ready-to-assemble furniture, drawer pulls and wherever ease of assembly or avoidance of thread stripping is desired. Install with hex drive wrench or E-Z LOK drive tool.



*Hole size requirements may vary depending on material and tools. We recommend that you test before ordering. We gladly supply free samples.

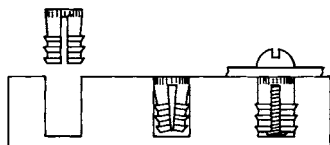

Finseks provide strong metal threads in wood, composition board and thermoplastics such as nylon, polystyrene, cellulose acetate and cycloc. By distributing stress over a greater surface area, firm permanent fastening is ensured. The fins give higher holding strength in softer materials. Available with one, two or three fins for varying material thickness, Finseks prevent splintering, splitting and thread pullout.

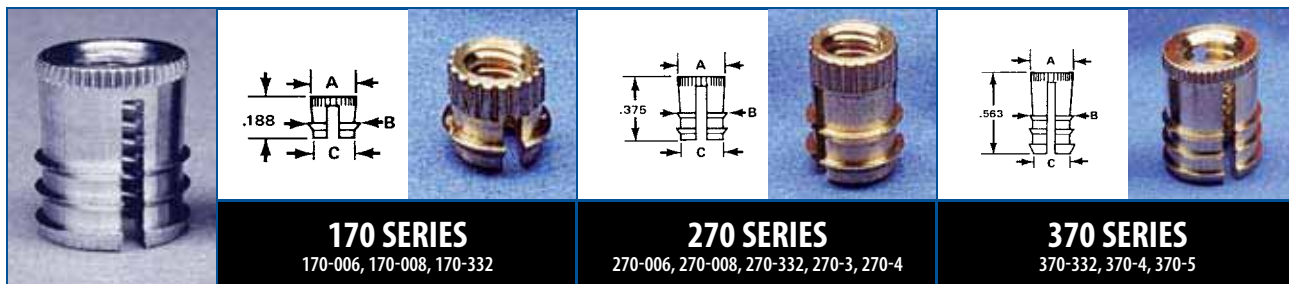

Thread Size	Dash Number	A	B	C	Starting Hole Size	A	B	C	Starting Hole Size	A	B	C	Starting Hole Size
6-32	—006	.210	.237	.189	.205 (#5)	.210	.237	.189	.205 (#5)	—	—	—	—
8-32	—008	.236	.263	.215	.234 (15/64)	.236	.263	.215	.234 (15/64)	—	—	—	—
10-32	—332	.263	.290	.242	.261 (G)	.263	.290	.242	.261 (G)	.347	.368	.318	.344 (11/32)
10-24	—3	—	—	—	—	.263	.290	.242	.261 (G)	—	—	—	—
1/4-20	—4	—	—	—	—	.330	.357	.309	.328 (21/64)	.409	.431	.381	.406 (13/32)
5/16-18	—5	—	—	—	—	—	—	—	—	.471	.493	.443	.469 (15/32)

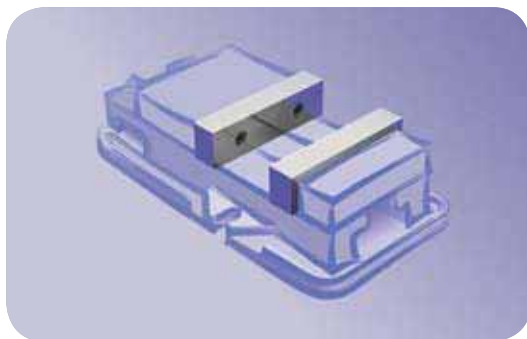

TCI ALUMINUM SOFT JAWS

Part Number	Vise Size	Jaw Dimensions		
		T(″)*	H(″)	L(″)
1610-3	3″	.730	1.250	4.000
1610-4	4″	.980	1.500	5.000
1610-5	5″	1.230	1.750	6.000
1610-6	6″	1.230	2.000	7.000
1610-8	8″	1.730	2.500	9.000
1610-10	10″	2.230	3.500	11.000

*All dimensions +/- .001″

FOR PRECISION MACHINE VISES

• HIGH PRECISION JAWS

Aircraft alloy aluminum flat and parallel within .001″.

• SAVE ON EXPENSIVE FIXTURES

Easy to customize jaws for mill or drill features.

• SAVE SET-UP TIME WHEN CHANGING JOBS

Leave vise on table...Remove 4 cap screws... Replace TCI Aluminum Soft Jaws...minimize set-up time.

• REUSABLE JAWS

Easy-to-machine aluminum allows inexpensive modifications.

• GET 2 FIXTURES FOR THE PRICE OF 1

Inverting jaws permits second fixture on the same pair of jaws.

• GENEROUS SIZE

Allows greater flexibility when building tooling.

• PROTECT FINISH

Aluminum Soft Jaws will not damage finish of parts.