

# IKO

Precision Elevating Table

# TZ

*The compact Precision Elevating Table has been newly released.*



CAT-57131

# High-precision, high-rigidity,

- The **IKO** original wedge mechanism incorporating a track rail is adopted.
- Two types of wedge reduction ratio can be selected according to the application.
- The product permits vertical positioning with the maximum stroke length of 24 mm.

**As a compact  
XYZ positioning unit ...**

**TZ120**

Precision Elevating Table

+

**CT**

Precision Positioning Table

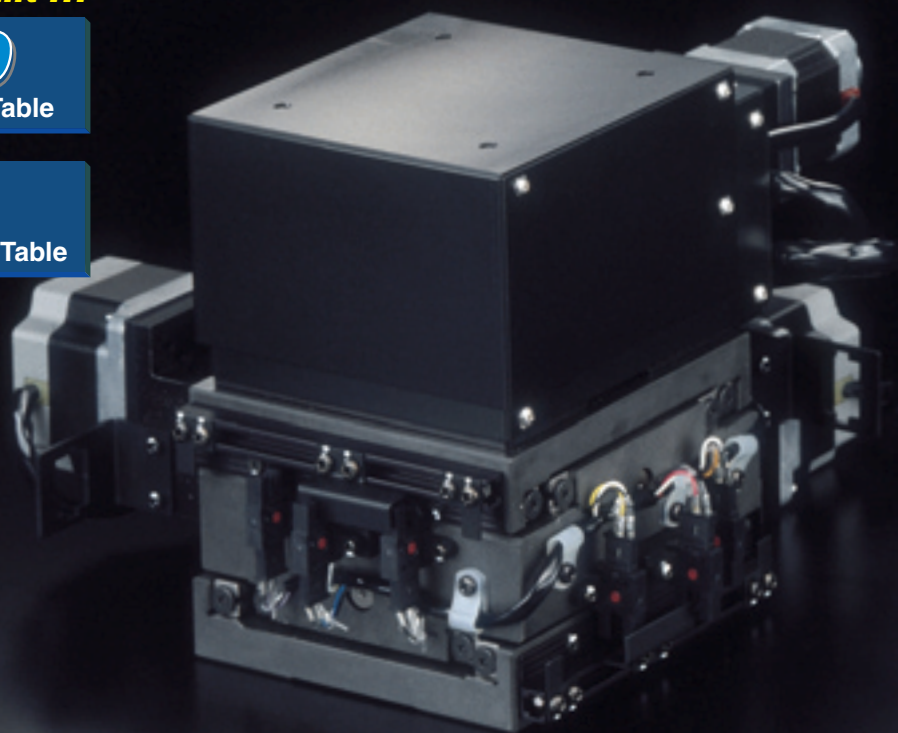

**Configuration example of the XYZ-axis positioning unit using Precision Elevating Table TZ**

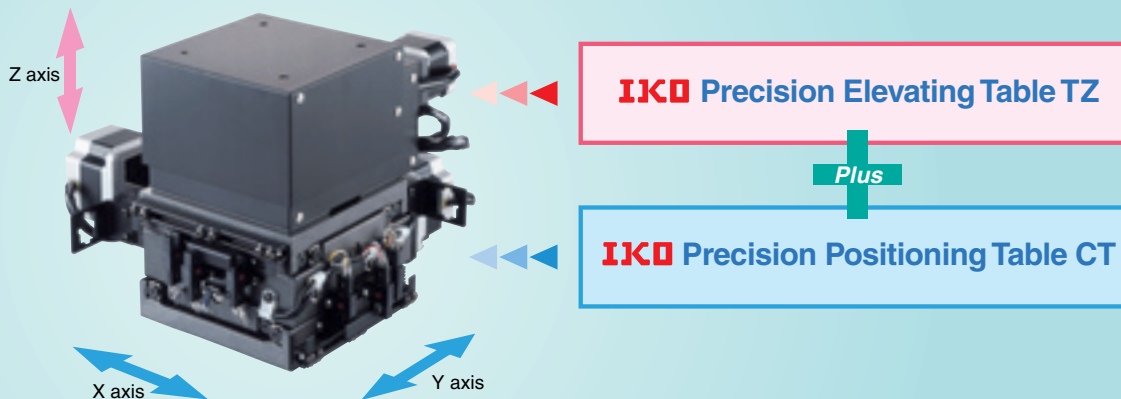

# and Compactness

As a compact  
XYZ positioning unit ...

**TZ200**

Precision Elevating Table

+

**CT**

Precision Positioning Table

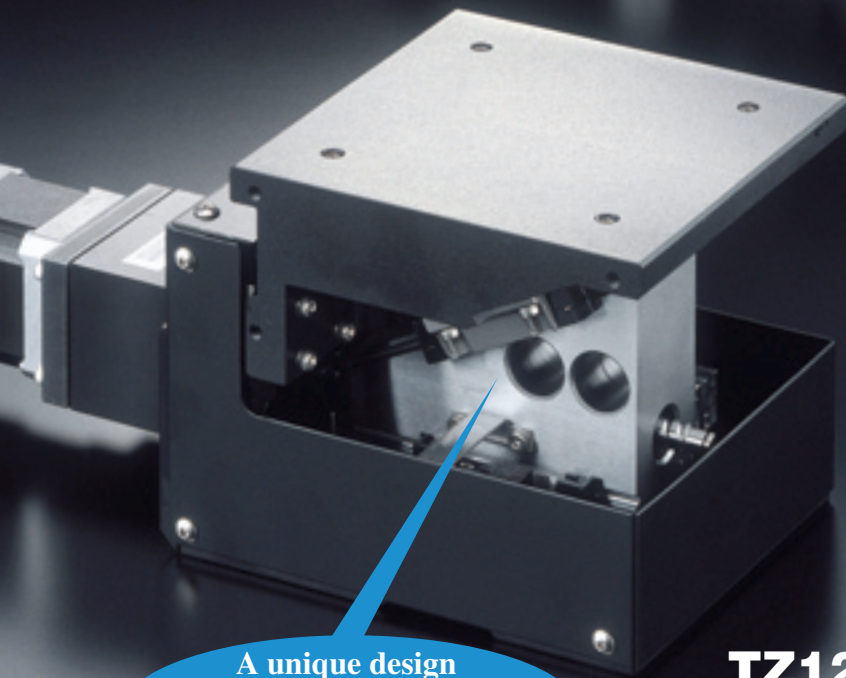

A unique design  
as a single-unit incorporating  
track rails and a wedge  
has been achieved.

**TZ120**

**IKO**

Precision Elevating Table

**TZ**

# IJK Precision Elevating Table TZ

IJK Precision Elevating Table TZ is an elevating table that performs precision positioning in the up and down directions by using the wedge mechanism.

The technology of IJK Linear Way with satisfactory results in various industrial machines is used for the wedge mechanism as it is. Incorporating track rail raceways and a wedge in a single-unit structure has achieved both high accuracy and high rigidity with a compact size.

IJK Precision Elevating Table is optimally applicable to semiconductor and liquid crystal manufacturing equipment and optical equipment which require a high positioning accuracy.

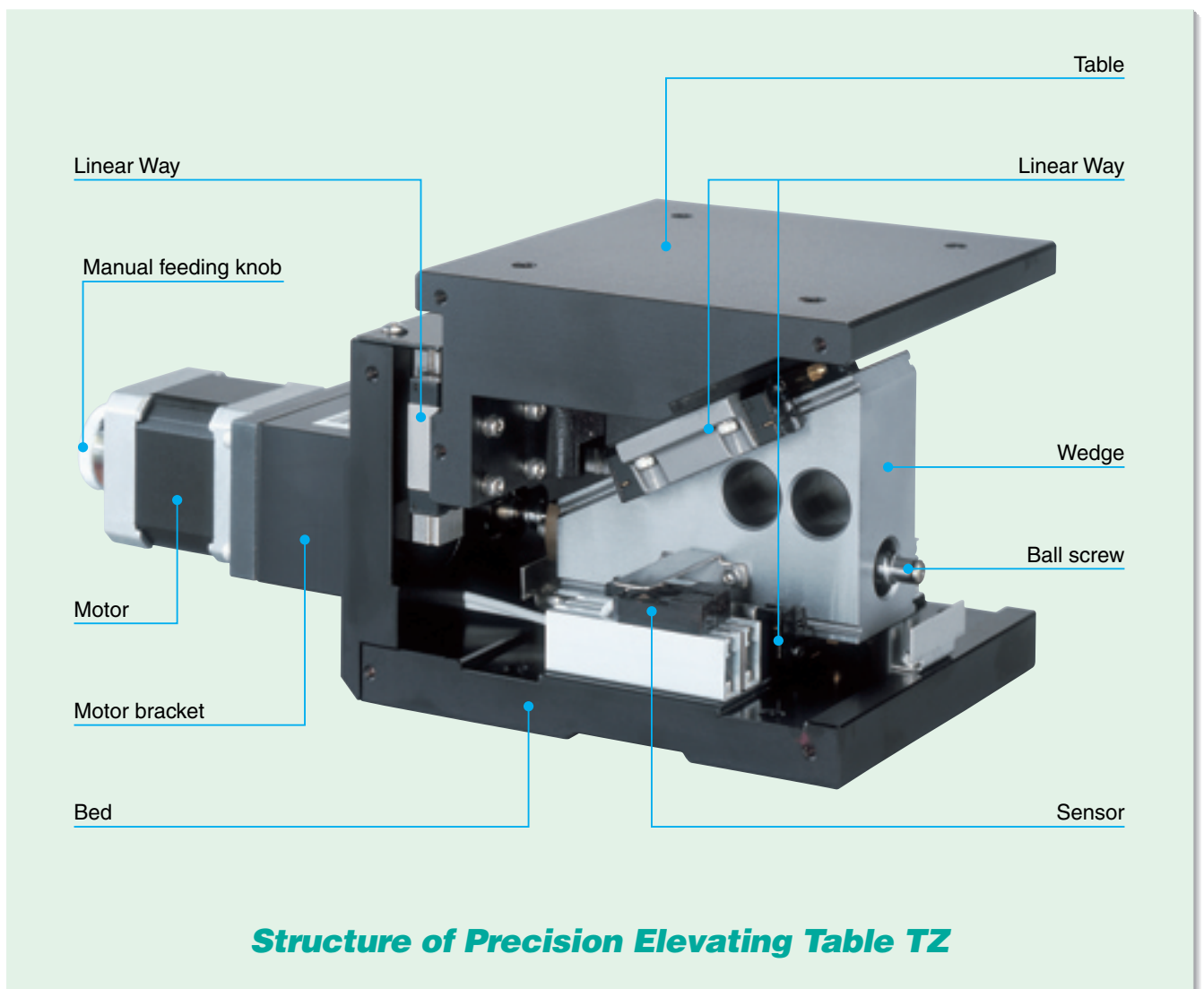

# Features

## ■ High accuracy and high positioning accuracy

High accuracy is achieved by incorporating three sets of Linear Way. This permits high-accuracy positioning.

## ■ Equipped with a sensor in the standard specification

In the standard specification, a limit sensor, origin sensor, and pre-origin sensor are equipped. These sensors are incorporated in the base in compact form. This facilitates mounting in the machines and equipment.

## ■ Compact size

Two sizes with a table size of 120mm X 120mm and 200mm X 200mm are available. Linear Way of the wedge and the track rail are incorporated as a single-unit structure. This achieves a compact size, securing high rigidity.

## ■ Two types of reduction ratios

Two types with a wedge reduction ratio 1:2 and 1:4 are available as new series. A suitable stroke length and resolution for each application can be selected.

## Variations of Precision Elevating Table TZ

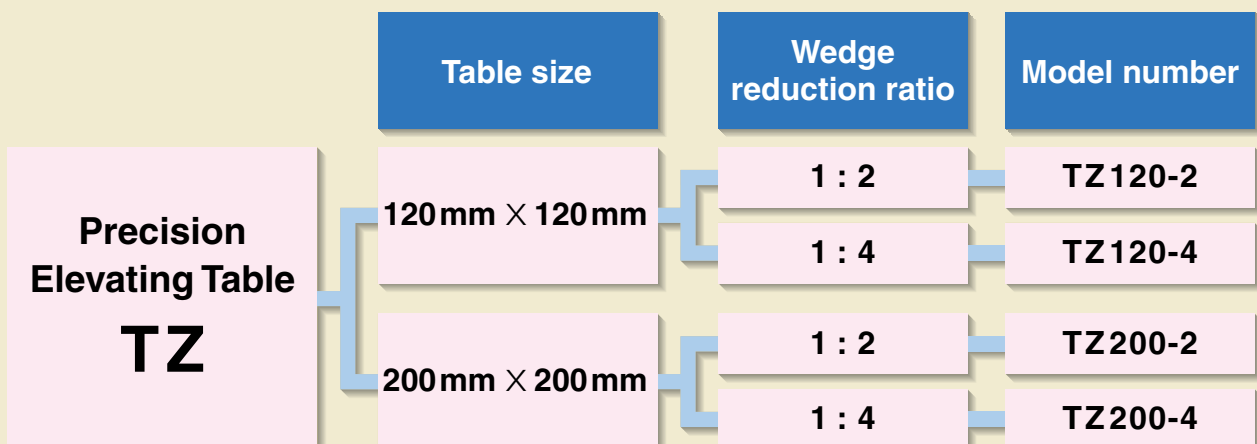

# Identification Number

An example of identification number of Precision Elevating Table TZ is shown below. Two sizes with a slide table plane size of 120mm × 120mm and 200mm × 200mm are available. A stepping motor or AC servo motor can be selected as a driving motor.

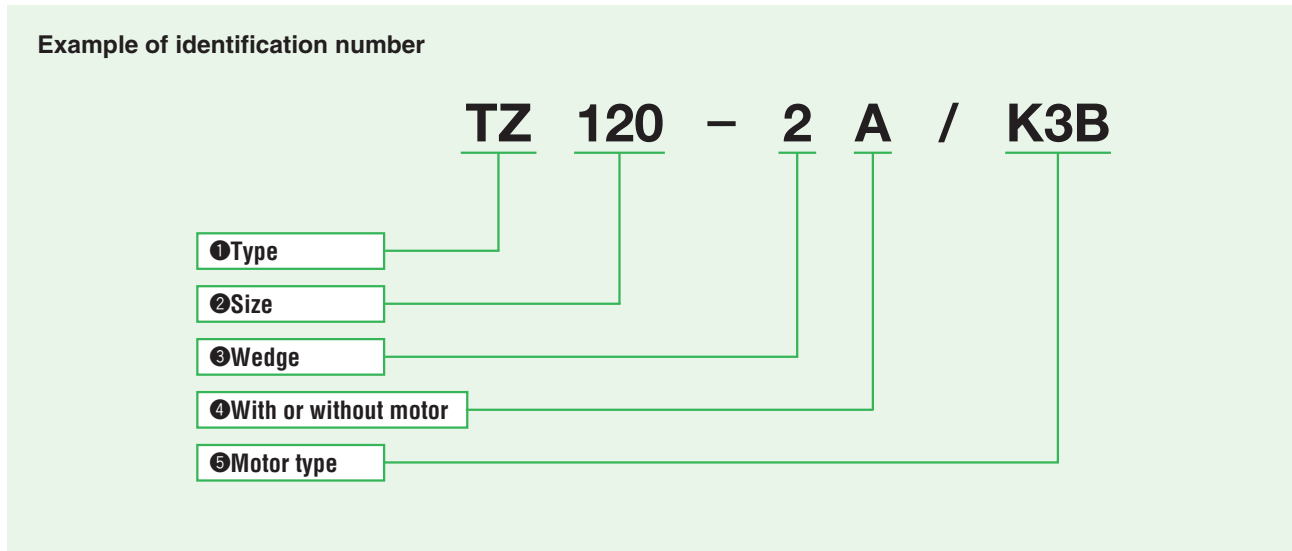

<b>①Type</b>	TZ: Precision Elevating Table TZ	
<b>②Size</b>	120: Size of slide table    120mm × 120mm 200: Size of slide table    200mm × 200mm	
<b>③Wedge</b>	2: Wedge reduction ratio 1:2 4: Wedge reduction ratio 1:4	This ratio indicates the reduction ratio of vertical travel amount to the ball screw feed amount.
<b>④With or without motor</b>	No symbol : Without motor A: With motor	When the motor is prepared on the customer side, specify "without motor" (no symbol).
<b>⑤Motor type</b>		Specify a motor code shown in Table 1. If "without motor" (no symbol) is specified in ④With or without motor, the motor attachment and coupling for each motor will be mounted.

**Table 1 Motor type and motor code**

Size	Motor type			
	AC servo motor		Stepping motor	
	Without brake	With brake	Without brake	With brake
<b>TZ 120</b>	A5	A5B	V002	K3B
<b>TZ 200</b>	A1	A1B	V003	K4B

# Characteristics

The characteristics of Precision Elevating Table TZ are shown in Table 2.

**Table 2 Characteristics**

Model number Item	Reduction ratio	Ball screw type	Ball screw lead mm	Resolution <sup>(1)</sup> μm / pulse	Repeatability mm	Stroke mm	Allowableload <sup>(2)</sup> Kg
<b>TZ 120-2</b>	1:2	Ground	4	2.00	±0.001	10	20
<b>TZ 120-4</b>	1:4			1.00		5	
<b>TZ 200-2</b>	1:2		5	2.50		24	40
<b>TZ 200-4</b>	1:4			1.25		12	

Note<sup>(1)</sup>: The resolution indicates a value when the number of motor divisions is 1000 pulses/rev.

Note<sup>(2)</sup>: The allowable load indicates the maximum load with which the table can be operated without causing any functional or performance trouble. The load that can guarantee the accuracy is about 1/2 of this value.

# Motor Specifications

For Precision Elevating Table TZ, a stepping motor or AC servo motor can be selected. A type with brake can also be specified. This allows the customer to make wide selection according to each application.

Table 3 shows the types of the standard motor. Table 4 shows the connector type used for each motors.

**Table 3 Types of standard motor**

Size	Motor type	With or without brake	Motor code	Model number	Remark
<b>TZ 120</b>	AC servo motor	Without brake	A5	SGM-A5B512	Yaskawa Electric Corporation
		With brake	A5B	SGM-A5B512B	
	Stepping motor	Without brake	V002	PK545-B	Oriental Motor Co., Ltd.
		With brake	K3B	A6088-9015KM	
<b>TZ 200</b>	AC servo motor	Without brake	A1	SGM-01B512	Yaskawa Electric Corporation
		With brake	A1B	SGM-01B512B	
	Stepping motor	Without brake	V003	PK564-B	Oriental Motor Co., Ltd.
		With brake	K4B	PK564-A-A25	

**Table 4 Types of applicable connectors**

Motor type	Connector type	Motor code		Type of motor-side connector		Type of opposite-side connector	
				Plug housing	Contact	Cap housing	Contact
AC servo motor	Motor connector	Without brake	A...	172167-1	170364-1	172159-1	170366-1
		With brake	A...B	172168-1		172160-1	
	Encoder connector	A...		172169-1	170359-1	172161-1	170361-1
Stepping motor	Motor connector	V... K...B		172170-1	170363-1	172162-1	170365-1

Remark 1. : The connector is a product manufactured by Tyco Electronics AMP K.K.

2. : Prepare the opposite-side connector on the customer side.

# Sensor Specifications

Table 5 shows the sensor specifications of Precision Elevating Table TZ and Table 6 shows the specifications of the sensor connector. Table 7 shows a sensor timing chart for the case where the stepping motor is specified

**Table 5 Specifications of sensors**

Item	Type	Limit, pre-origin sensors	Origin sensor
Type		Proximity sensor	
Power supply voltage		DC12~24V ±10%	
Current consumption		10 mA or less	
Output		Open collector · Maximum current : 100mA · Applied voltage : DC 30 V or less · Residual voltage : 1.0 V or less at 100 mA in-flow current 0.4 V or less at 16 mA	
Output operation		When approaching: OFF	When approaching: ON
Operation indicator		LED (red)	
Circuit diagram			

**Table 6 Specifications of sensor connectors**

Pin No.	Signal name	Sensor-side connector type	Opposite-side connector type
1	Origin	Cap housing 172160-1	Plug housing 172168-1
2	Pre-origin		
3	CW limit		
4	CCW limit	Contactor 170365-1	Contactor 170363-1
5	Power input		
6	GND		

- Remark 1. : The connector is a product manufactured by Tyco Electronics AMP K.K  
 2. : Prepare the opposite-side connector on the customer side.  
 3. : When the AC servo motor is used, the origin sensor is not attached. Use the C-phase or Z-phase signal of the encoder.

**Table 7 Timing chart of sensors**

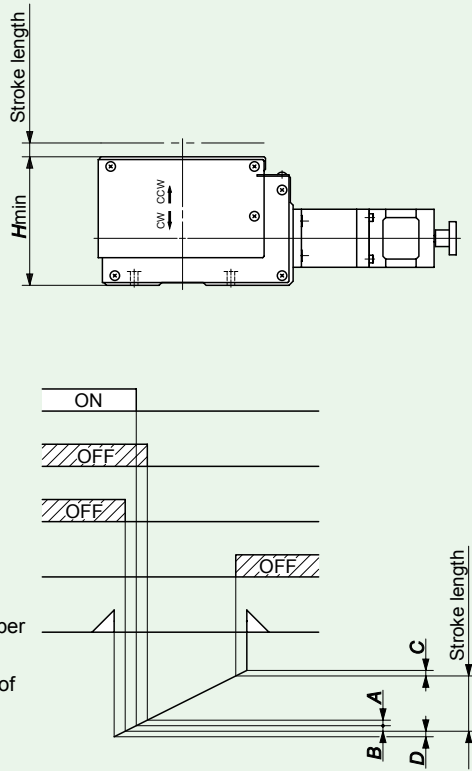

unit : mm

Model number	A	B	C	D
<b>TZ 120-2</b>	1	1	1	1
<b>TZ 120-4</b>	0.5	0.5	0.5	0.5
<b>TZ 200-2</b>	1.5	1	1	1
<b>TZ 200-4</b>	0.75	0.5	0.5	0.5

# IJK Precision Elevating Table TZ

## TZ 120

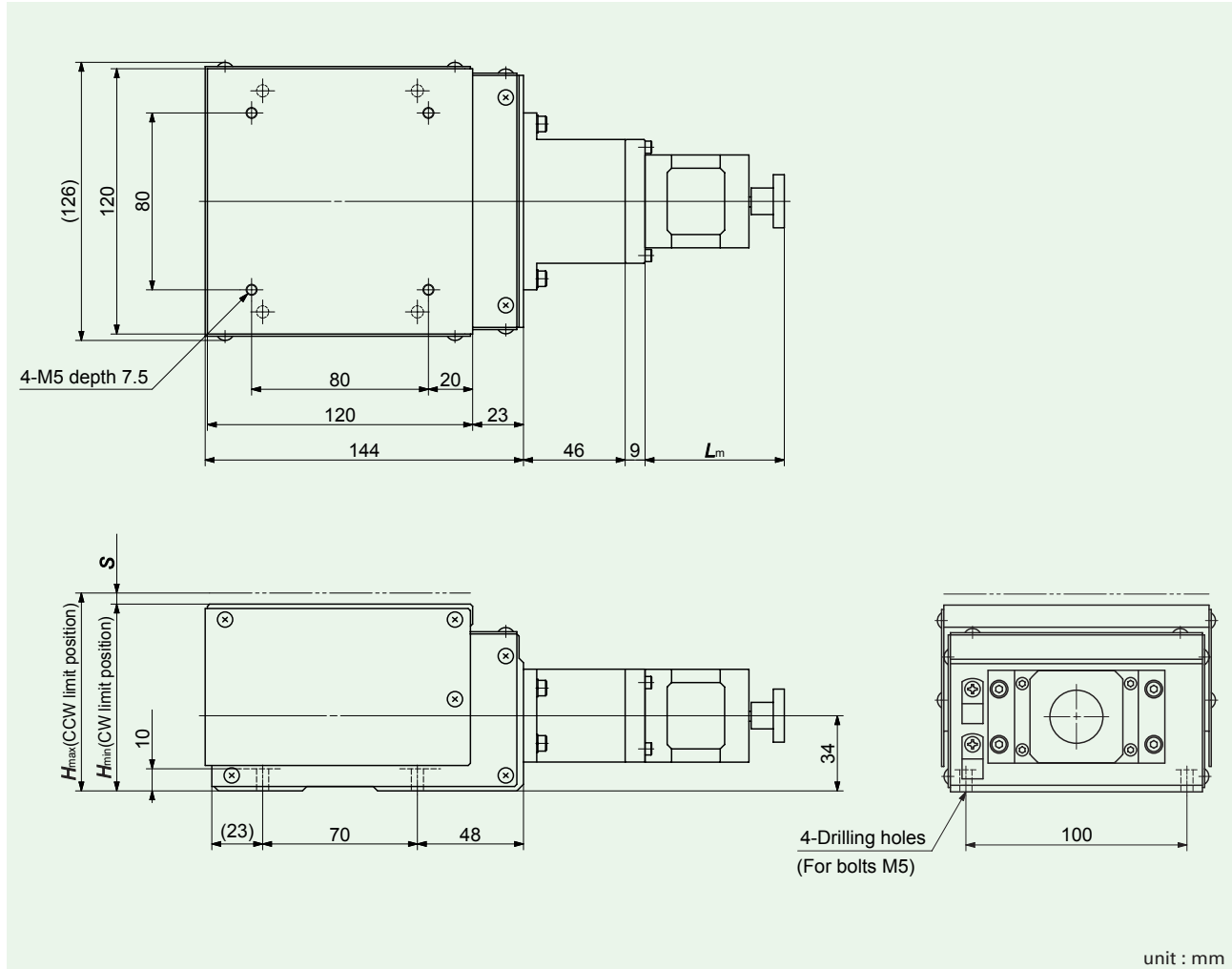

unit : mm

Model number	Wedge reduction ratio	Mass <sup>(1)</sup> (Reference) kg	Height		Stroke length S
			Hmin	Hmax	
<b>TZ 120-2</b>	1:2	3.8	93	103	10
<b>TZ 120-4</b>	1:4	3.4	84.5	89.5	5

Note<sup>(1)</sup>: The mass of the motor is not included.

### Dimension of motors

unit : mm

Model number	Motor type	With or without brake	Motor code	Lm
<b>TZ 120-2</b> <b>TZ 120-4</b>	AC servo motor	Without brake	A5	77 <sup>(1)</sup>
		With brake	A5B	108.5 <sup>(1)</sup>
	Stepping motor	Without brake	V002	63
		With brake	K3B	77 <sup>(1)</sup>

Note<sup>(1)</sup>: The end part of the motor is not provided with any manual operation knob.

# IJK Precision Elevating Table TZ

## TZ 200

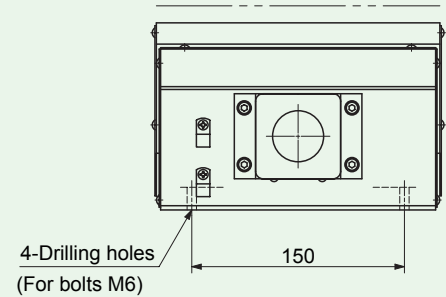
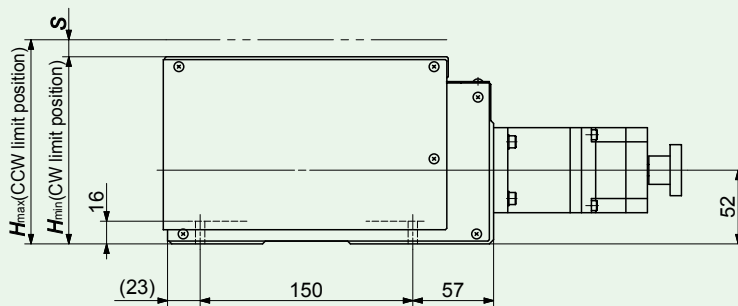
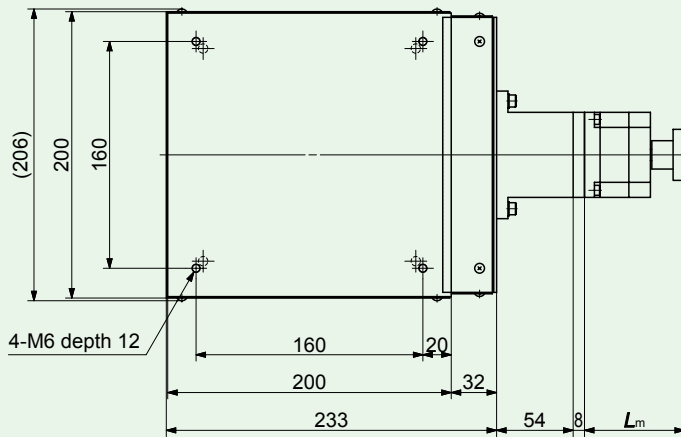

unit : mm

Model number	Wedge reduction ratio	Mass <sup>(1)</sup> (Reference) kg	Height		Stroke length S
			Hmin	Hmax	
<b>TZ 200-2</b>	1:2	12.4	146	170	24
<b>TZ 200-4</b>	1:4	11.8	132	144	12

Note<sup>(1)</sup>: The mass of the motor is not included.

### Dimension of motors

unit : mm

Model number	Motor type	With or without brake	Motor code	Lm
<b>TZ 200-2</b> <b>TZ 200-4</b>	AC servo motor	Without brake	A1	94.5 <sup>(1)</sup>
		With brake	A1B	135 <sup>(1)</sup>
	Stepping motor	Without brake	V003	70.5
		With brake	K4B	88.5 <sup>(1)</sup>

Note<sup>(1)</sup>: The end part of the motor is not provided with any manual operation knob.

# TZ

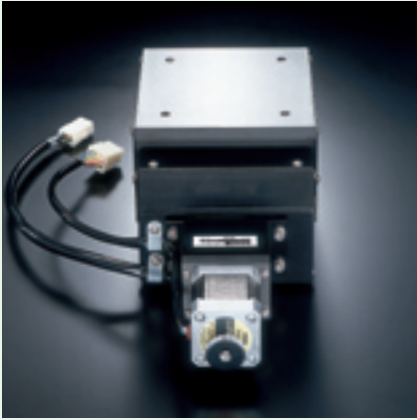

## **NIPPON THOMPSON CO., LTD.**

Head office : 19-19 Takanawa 2-chome  
Minato-ku, Tokyo 108-8586, Japan  
Phone : Tokyo (03)3448-5850  
Fax : (03)3447-7637  
E-mail : [ntt@ikonet.co.jp](mailto:ntt@ikonet.co.jp)  
URL : <http://www.ikont.co.jp/eg/>  
Plant : Gifu, Kamakura

Although all data in this catalog has been carefully compiled to make the information as complete as possible, NIPPON THOMPSON CO., LTD. shall not be liable for any damages whatsoever, direct or indirect, based upon any information in this catalog. NIPPON THOMPSON CO., LTD. makes no warranty, either express or implied, including the implied warranty of merchantability or fitness for a particular purpose.