



Precision Positioning Table

TS·CT

CAT-57122

Smallest size compact series is now available !



Compact, high accuracy, and high rigidity

Table width 55 to 350 mm



TS 55/55 and CT 55/55

Ⓜ Precision Positioning Table is a positioning table, consisting of a slide table and bed of cast iron with high rigidity and excellent vibration damping performance. Ⓜ Crossed Roller Way, a widely used precision linear motion rolling guide, is assembled in the slide table and bed, and a precision ball screw is used in the travel mechanism.

By making the most of the features of compact, high accuracy, and high rigidity Ⓜ Crossed Roller Way, a high accuracy positioning table with a low sectional height and high reliability has been achieved.

Ⓜ Precision Positioning Table is available in two types, namely, single-axis type and two-axis type, and these are widely used in precision measuring instruments, precision assemblers, and other equipment that require high accuracy positioning.

IKO Precision Positioning Table TS·CT

Features of TS·CT

1

Low sectional height and compact

The optimal design using IKO Crossed Roller Way as a linear motion rolling guide has achieved a low sectional height even in the two-axis specification.

The center of gravity of machines and equipment can be lowered.

2

High accuracy positioning

High travel and positioning accuracy of the table is achieved by precisely grinding the cast iron slide table and bed and assembling carefully chosen high accuracy components on them.

3

Compact design with the wide surface area of slide table

The surface area of the slide table is large compared with the stroke length, so the top surface of the table can be used as work area.

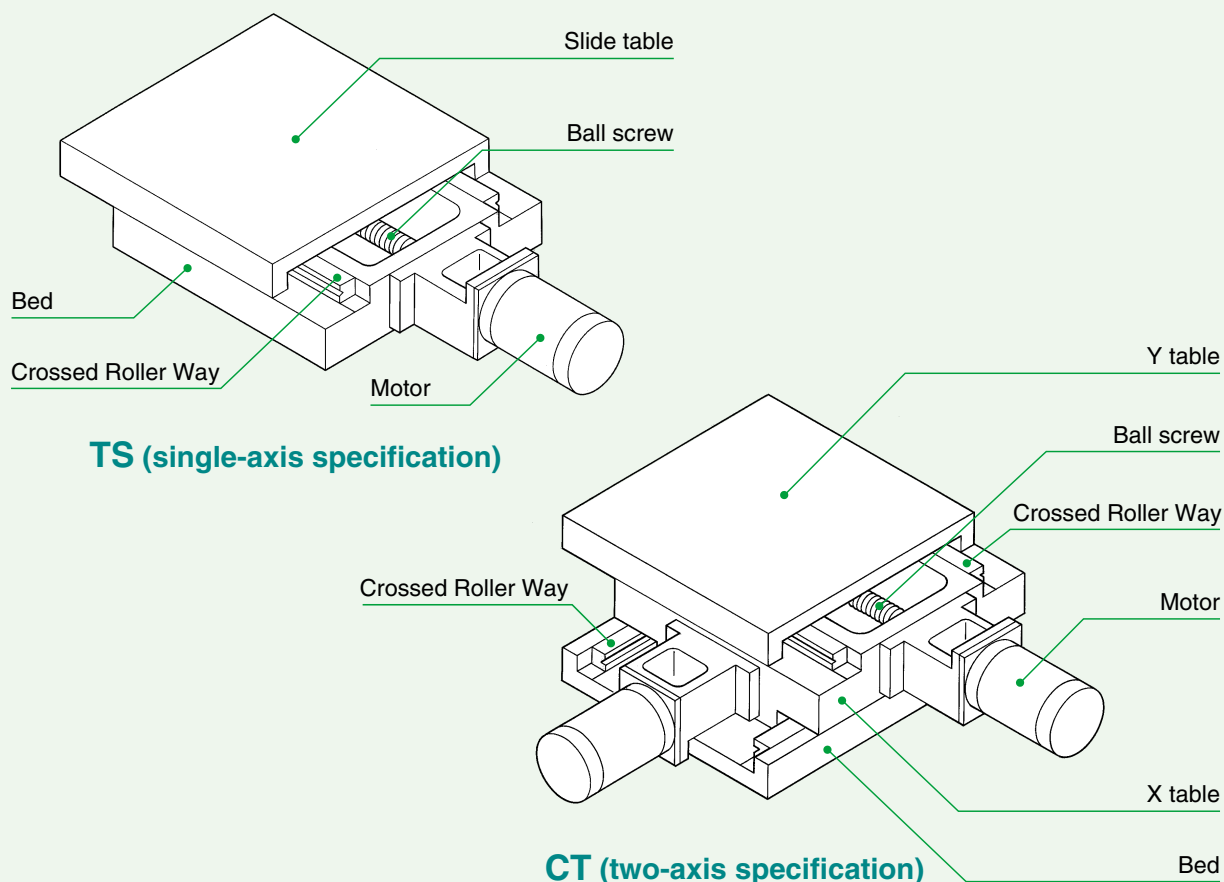

Structure of Precision Positioning Table

Identification Number

Example of identification number

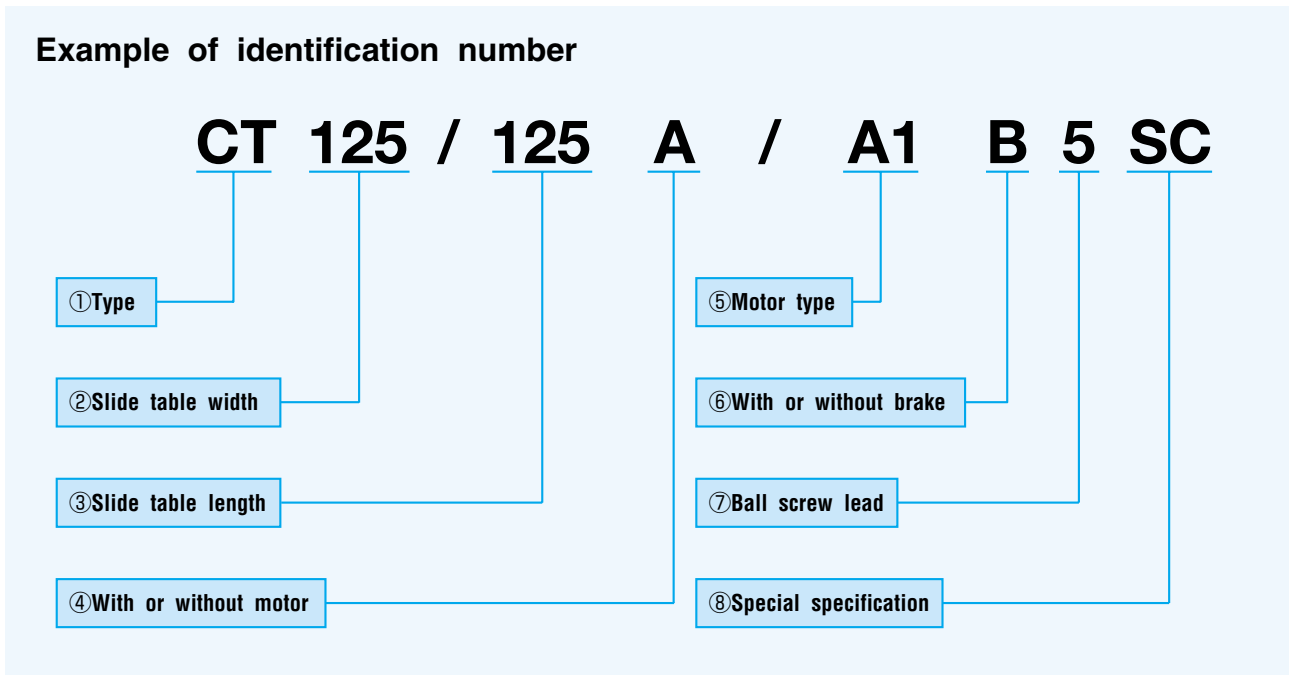

① Type	TS : Precision Positioning Table (single-axis specification) CT : Precision Positioning Table (two-axis specification)
---------------	---

②③ Size of slide table	Slide table sizes shown in Table 1 can be selected.
-------------------------------	---

Slide table width and length are indicated in mm. For CT (two-axis specification), Y table width and length are indicated.

Table 1 Size of slide table

Type	Width/length mm
TS	55/55, 75/75, 125/125, 125/220, 220/220, 220/310, 260/350
CT	55/55, 75/75, 125/125, 220/220, 260/350, 350/350

④ With or without motor	No symbol : Without motor A : With motor
--------------------------------	---

If the customer provides a motor, specify “without motor” (no symbol).

⑤ No symbol : Without motor	Motor codes shown in Table 2 can be selected.
------------------------------------	---

When “without motor” is selected in item ④, the motor attachment and coupling prepared for the specified motor will be attached.

Table 2 Motor type and motor code

Motor type	Slide table size			
	55/55 75/75	125/125	125/220 220/220 220/310	260/350 350/350
AC servo motor	—	A1, M1	A1, M1	A2, M2
Stepping motor	S2	K4	K5	K7

⑥With or without brake	No symbol : Without brake B : With brake (not applicable to 55/55 and 75/75)
-------------------------------	---

If a motor with brake is required, specify “with brake” (code B). For CT (two-axis specification), however, a motor with brake is provided only for the Y axis.

⑦Ball screw lead	1 : Lead 1 mm (applicable to 55/55, 75/75, and 125/125) 2 : Lead 2 mm (not applicable to 55/55 and 75/75) 5 : Lead 5 mm (not applicable to 55/55 and 75/75)
-------------------------	---

⑧Special specification	No symbol : Standard specification AL : Aluminum alloy made table (not applicable to 55/55 and 75/75) LR : Black chrome surface treatment SC : Table with sensors BE : Option base (applicable to 55/55)
-------------------------------	--

Aluminum alloy made table : Specification in which the slide table, bed, and motor bracket are made of cast aluminum alloy. The accuracy is different from that of the standard specification.

Black chrome surface treatment : A black permeable film is formed on the surface to improve corrosion resistance. This treatment is performed on the slide table, bed, and motor bracket. The surface treatment film is removed from the reference surface of each part.

Table with sensors : A set of limit sensors, pre-origin sensor, and origin sensor is attached. However, when the AC servo motor is selected, the origin sensor is not attached. Use the C-phase or Z-phase signal of the encoder.

Maximum Speed and Resolution

■Maximum speed

The maximum speed of Precision Positioning Table can be obtained by the following formula. For the ball screw drive type, the maximum speed may be limited by the allowable rotation speed of the ball screw depending on the stroke length. Refer to the item pertaining to “Characteristics” of each type.

Ball screw drive

$$\text{Maximum speed (mm/s)} = \text{Ball screw lead (mm)} \times \frac{\text{Maximum motor rotation speed (r/min)}}{60}$$

The actual positioning time must be determined by selecting an operation pattern considering the acceleration/deceleration time, stroke length, etc. Refer to the item pertaining to “Selecting an operation pattern”.

■Resolution

Resolution means the minimum feed amount of Precision Positioning Table, and can be obtained by the following formula.

Ball screw drive

$$\text{Resolution (mm/pulse)} = \frac{\text{Ball screw lead (mm)}}{\text{Number of divisions per motor rotation (pulse)}}$$

Selecting an operation pattern

The maximum speed of the table can be determined from the maximum speed of the motor and the lead of the ball screw. For calculating the actual positioning time, the acceleration/deceleration time must also be taken into consideration. Furthermore, the effective torque in the operation pattern must be examined to check whether it is equal to or less than the rated torque of the motor.

Calculating the limit acceleration time

The torque acting on the motor is the sum of the torque due to load and that due to acceleration. It reaches its peak during acceleration. Considering that the torque required for acceleration can not exceed the output torque of the motor, the limit acceleration time is calculated as follows:

●Load torque T_L

$$T_L = T_0 + \mu Wg \cdot \frac{\ell}{2\pi\eta} \quad [\text{N}\cdot\text{m}]$$

●Acceleration torque T_a

$$T_a = (J_M + J_T + J_L) \cdot \frac{2\pi N}{60t_a} \quad [\text{N}\cdot\text{m}]$$

$$J_L = W \cdot \left(\frac{\ell}{2\pi}\right)^2 \quad [\text{kg}\cdot\text{m}^2]$$

●Torque required for acceleration T_P

$$T_P = T_L + T_a \quad [\text{N}\cdot\text{m}]$$

$$T_P < T_M$$

●Limit acceleration time t_a

$$t_a = (J_M + J_T + J_L) \cdot \frac{2\pi N}{60} \cdot \frac{k}{T_M - T_L} \quad [\text{s}]$$

- T_0 : Start-up torque N·m
- μ : Friction coefficient of the rolling guide 0.01
- W : Weight of the load (Mass put on the table) kg
- ℓ : Lead of the ball screw m
- η : Efficiency 0.9
- J_M : Motor inertia kg·m²
- J_T : Table inertia kg·m²
- J_L : Inertia of the load kg·m²
- N : Motor speed rpm
- t_a : Acceleration time s
- g : Gravitational acceleration 9.8m/s²
- T_M : Output torque of the motor N·m
 - T_M of the stepping motor can be obtained from the torque characteristic diagram by picking up the output torque at a motor speed of N .
 - T_M of the AC/DC servo motor must be set to 2 or 3 times the rated torque.
- k : Constant
 - Stepping motor : 1.5~2
 - AC/DC servo motor : 1.3

Calculating an effective torque

An AC/DC servo motor requires a large torque during the table acceleration/deceleration.

If, in an operation pattern, the ratio of running time of motor is high, the effective torque may exceed the rated torque of the motor, and the motor may over-heat or seize. Therefore, make sure that the effective torque does not exceed the rated torque of the motor.

The effective torque is obtained as follows, when the table is driven in the operation pattern shown in Fig. 7:

●Effective torque T_{rms}

$$T_{rms} = \sqrt{\frac{T_P^2 \times t_a \times 2 + T_L^2 \times t_c}{t}} \quad [\text{N}\cdot\text{m}]$$

For simplification, it is assumed: torque in acceleration=torque in deceleration

If the rated torque of the motor is higher than the effective torque, the motor can run continuously in that operation pattern.

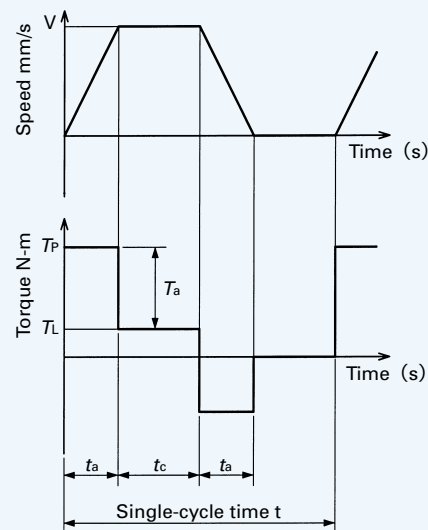

Fig. 1 Operation pattern and required torque

Table Characteristics and Motor Specification

Table 3 Accuracy

unit : mm

Table size		Positioning accuracy	Repeatability	Parallelism in table operation A	Parallelism in table operation B	Perpendicularity between X and Y motions ⁽¹⁾
Single-axis specification	Two-axis specification					
TS 55/ 55	—	0.005	±0.002 (±0.003)	0.005 (0.008)	0.015 (0.022)	0.005
—	CT 55/ 55	0.010				
TS 75/ 75	CT 75/ 75	0.005				
TS125/125	CT125/125	(0.008)				
TS125/220	—	0.008		0.008 (0.012)	0.020 (0.030)	0.008
TS220/220	CT220/220	(0.012)				
TS220/310	—	0.015				
TS260/350	CT260/350	(0.025)				
—	CT350/350					

Note⁽¹⁾ : Applicable to two-axis specification tables.

Remark : The values in () are those for aluminum alloy made tables (special specification AL) that are different from those of the standard specification tables.

Table 4 Maximum speed

Motor type	Maximum speed r/min	Motor rotation speed mm/s		
		Lead 1mm	Lead 2mm	Lead 5mm
AC servo motor	3000	50	100	250
Stepping motor	1800	30	60	150

Remark : The above table shows values when the standard motor is used. The actual maximum speed must be determined by selecting an operation pattern considering the motor used, load conditions, etc.

Table 5 Allowable load

Table size		Single-axis specification N
Single-axis specification	Two-axis specification	
TS 55/ 55	CT 55/ 55	20
TS 75/ 75	CT 75/ 75	50
TS125/125	CT125/125	250
TS125/220	—	280
TS220/220	CT220/220	300
TS220/310	—	400
TS260/350	—	500
—	CT260/350	350
—	CT350/350	500

Remark : Allowable load means the maximum load that can be applied on the table without causing any trouble in function and performance. However, the load at which accuracy can be guaranteed is 1/2 of the values in the table.

Table 6 Table inertia J_T and start-up torque T_0

Table size		Table inertia J_T $\times 10^{-9} \text{kg-m}^2$			Start-up torque T_0 N-m
		Lead 1mm	Lead 2mm	Lead 5mm	
Single-axis specification	TS 55/ 55	0.01	—	—	0.03
	TS 75/ 75	0.01	—	—	
	TS125/125	0.20	0.23	0.55	
	TS125/220	—	0.40	0.95	
	TS220/220	—	0.73	1.1	
	TS220/310	—	1.3	2.1	
	TS260/350	—	3.8	5.6	
Two-axis specification	CT 55/ 55	X axis	0.01	—	0.03
		Y axis	0.01	—	
	CT 75/ 75	X axis	0.01	—	0.07
		Y axis	0.01	—	
	CT125/125	X axis	0.20	0.28	0.07
		Y axis	0.20	0.23	
	CT220/220	X axis	—	0.85	0.07
		Y axis	—	0.73	
	CT260/350	X axis	—	4.6	0.07
		Y axis	—	3.8	
	CT350/350	X axis	—	4.9	0.07
		Y axis	—	4.6	

Table 7 Types of standard motors

Table size	Motor type	With or without brake	Motor code	Model number	Remark
TS 55/ 55 TS 75/ 75 CT 55/ 55 ⁽¹⁾ CT 75/ 75 ⁽¹⁾	Stepping motor	Without brake	S2	PX535MH-A	Oriental Motor Co., Ltd.
TS125/125 CT125/125 ⁽¹⁾	AC servo motor	Without brake	A1	SGM-01B512	Yaskawa Electric Corporation
			M1	MSM011A1A	Matsushita Electric Industrial Co., Ltd.
		With brake	A1B	SGM-01B512B	Yaskawa Electric Corporation
			M1B	MSM011A1B	Matsushita Electric Industrial Co., Ltd.
	Stepping motor	Without brake	K4	PK564-A	Oriental Motor Co., Ltd.
		With brake	K4B	PK564-A-A25	
TS125/220 TS220/220 TS220/310 CT220/220 ⁽¹⁾	AC servo motor	Without brake	A1	SGM-01B512	Yaskawa Electric Corporation
			M1	MSM011A1A	Matsushita Electric Industrial Co., Ltd.
		With brake	A1B	SGM-01B512B	Yaskawa Electric Corporation
			M1B	MSM011A1B	Matsushita Electric Industrial Co., Ltd.
	Stepping motor	Without brake	K5	PK566-A	Oriental Motor Co., Ltd.
		With brake	K5B	PK566-A-A25	
TS260/350 CT260/350 ⁽¹⁾ CT350/350 ⁽¹⁾	AC servo motor	Without brake	A2	SGM-02B512	Yaskawa Electric Corporation
			M2	MSM021A1A	Matsushita Electric Industrial Co., Ltd.
		With brake	A2B	SGM-02B512B	Yaskawa Electric Corporation
			M2B	MSM021A1B	Matsushita Electric Industrial Co., Ltd.
	Stepping motor	Without brake	K7	PK596-A	Oriental Motor Co., Ltd.
		With brake	K7B	PK596-A-A25	

Note⁽¹⁾ : In tables with brake, a motor with brake is provided only for the Y axis.

Table 8 Specifications of standard motors (AC servo motors)

Motor code	A5	M5	A1	M1	A2	M2	AA4	MA4	AA8	MA8
Model number	SGM-A5B512	MSM5AZA1A	SGM-01B512	MSM011A1A	SGM-02B512	MSM021A1A	SGM-04A512	MSM042A1A	SGM-08A512	MSM082A1A
Voltage specification V	100		100		100		200		200	
Rated output W	50		100		200		400		750	
Rated torque N-m	0.159	0.16	0.318	0.32	0.637	0.64	1.27	1.3	2.39	2.4
Instantaneous maximum torque N-m	0.48	0.48	0.96	0.95	1.91	1.91	3.82	3.8	7.1	7.15
Rated motor speed r/min	3000	3000	3000	3000	3000	3000	3000	3000	3000	3000
Instantaneous maximum motor speed r/min	4500	5000	4500	5000	4500	5000	4500	5000	4500	5000
Motor inertia J_M kg-m ²	0.26×10^{-5}	0.27×10^{-5}	0.40×10^{-5}	0.63×10^{-5}	1.23×10^{-5}	1.7×10^{-5}	1.91×10^{-5}	3.7×10^{-5}	6.71×10^{-5}	13.3×10^{-5}
Number of divisions of encoder pulse/rev.	2000	2500	2000	2500	2000	2500	2000	2500	2000	2500
Mass (Ref.) kg	0.4	0.31	0.5	0.53	1.1	0.96	1.7	1.6	3.4	3.1
Applicable driver	TDA1-1004	—	TDA1-1004	—	TDA1-2004	—	—	—	—	—
Applicable control unit	NCD160G-A0500		NCD160G-A2006				—	—	—	—

Remark : SGM (motor code : A···) : manufactured by Yaskawa Electric Corporation, MSM (motor code : M···) : manufactured by Matsushita Electric Industrial Co., Ltd.

Table 9 Specifications of standard motors (stepping motors)

Motor code	S1	S2	K3	K4	K5	K6	K7	K8
Model number	PH533-A	PX535MH-A	PK545-A	PK564-A	PK566-A	PK569-A	PK596-A	PK599-A
Basic step angle	0.72°	0.36°	0.72°	0.72°	0.72°	0.72°	0.72°	0.72°
Excitation maximum static torque N-m	0.027	0.135	0.24	0.42	0.83	1.66	2.1	4.1
Current A/phase	0.75	0.75	0.75	0.75	0.75	1.4	1.4	1.4
Winding resistance Ω/phase	1.8	1.5	2.2	2.3	3.4	1.7	1.5	2.3
Motor inertia J_M kg-m ²	0.09×10^{-5}	0.35×10^{-5}	0.68×10^{-5}	1.75×10^{-5}	2.8×10^{-5}	5.6×10^{-5}	14×10^{-5}	27×10^{-5}
Mass (Ref.) kg	0.11	0.17	0.35	0.6	0.8	1.3	1.7	2.8
Applicable driver	TDS1-5071 TDS1-5145	TDS1-5071 TDS1-5145	TDS1-5071 TDS1-5145	TDS1-5071 TDS1-5145	TDS1-5071 TDS1-5145	TDS1-5145	TDS1-5145	TDS1-5145

Remark : These motors are manufactured by Oriental Motor Co., Ltd.

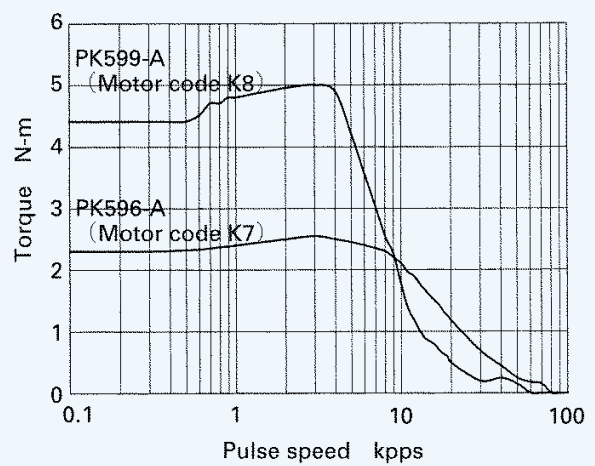
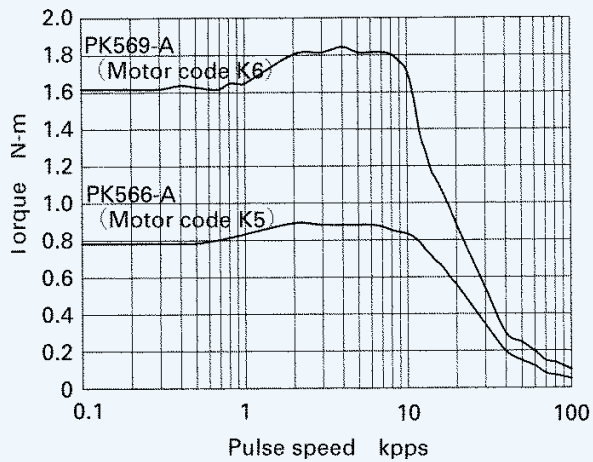
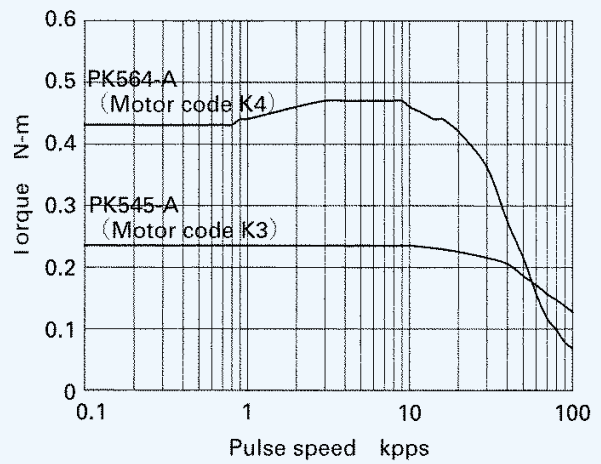
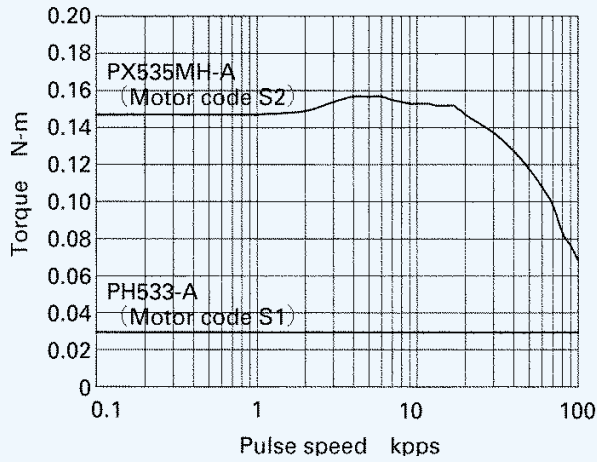

Fig. 2 Torque characteristic diagrams of standard stepping motors

Remark : The above figures are torque characteristic diagrams when the motor is combined with TDS1-5145 and is driven at a half step.

Table 10 Specifications of connectors (AC servo motor : motor code A···)

Connector		Pin No.	Signal name	Cover color of lead wire	Connector used (Manufactured by AMP)			
					Motor side	Mating side		
Motor connector	Without brake	1	U-phase	Red	Plug housing 172167-1	Cap housing 172159-1		
		2	V-phase	White				
		3	W-phase	Blue				
		4	FG (frame ground)	Green				
	With brake	1	U-phase	Red	Plug housing 172168-1	Cap housing 172160-1		
		2	V-phase	White				
		3	W-phase	Blue				
		4	FG (frame ground)	Green				
		5	Brake input	Red			Contactor 170364-1	Contactor 170366-1
		6	Brake input	Black				
Encoder connector	1	Channel A output+	Blue	Plug housing 172169-1	Cap housing 172161-1			
	2	Channel A output-	Blue/black					
	3	Channel B output+	Yellow					
	4	Channel B output-	Yellow/black					
	5	Channel C output+	Green					
	6	Channel C output-	Green/black					
	7	GND (power input)	Gray			Contactor 170359-1	Contactor 170361-1	
	8	+5V (power input)	Red					
	9	FG (frame ground)	Orange					

Remark : Prepare mating-side connectors at the customer side.

Table 11 Specifications of connectors (AC servo motor : motor code M···)

Connector		Pin No.	Signal name	Cover color of lead wire	Connector used (Manufactured by AMP)		
					Motor side	Mating side	
Motor connector	1	U-phase	Red	Plug housing 172167-1	Cap housing 172159-1		
	2	V-phase	Yellow				
	3	W-phase	Black				
	4	FG (frame ground)	Green/yellow				
Brake connector	1	Brake input	Yellow	Plug housing 172165-1	Cap housing 172157-1		
	2	Brake input	Yellow	Contactor 170360-1	Contactor 170362-1		
Encoder connector	1	A-phase output+	Red	Plug housing 172171-1	Cap housing 172163-1		
	2	A-phase output-	Pink				
	3	B-phase output+	Green				
	4	B-phase output-	Blue				
	5	Z-phase output+	Yellow				
	6	Z-phase output-	Orange				
	11	RX+	Light blue			Contactor 170359-1	Contactor 170361-1
	12	RX-	Purple				
	13	+5V (power input)	White				
	14	GND (power input)	Black				
	15	FG (frame ground)	Black				

Remark : Prepare mating-side connectors at the customer side.

Table 12 Specifications of connectors (Stepping motor : motor code S··, K··)

	Pin No.	Cover color of lead wire	Connector used (Manufactured by AMP)	
			Motor side	Mating side
Without brake	1	Gray	Plug housing 172170-1 Contactor 170363-1	Cap housing 172162-1 Contactor 170365-1
	2	Purple		
	3	Orange		
	4	Black		
	5	Brown		
	6	White		
	7	Yellow		
	8	Red		
	9	Blue		
	10	Green		
	11	Not used		
	12	Not used		
With brake	1	Gray	Plug housing 172170-1 Contactor 170363-1	Cap housing 172162-1 Contactor 170365-1
	2	Purple		
	3	Orange		
	4	Black		
	5	Brown		
	6	White		
	7	Yellow		
	8	Red		
	9	Blue		
	10	Green		
	11	(Brake input -)		
	12	(Brake input +)		

Remark : Prepare mating-side connectors at the customer side.

Sensor specification

CW and CCW limit sensors for preventing overrun and pre-origin and origin sensors for detecting the mechanical origin are prepared for installation on Precision Positioning Table. If required, specify the installation of these sensors by the identification number.

Table 12 shows the types of sensors used in Precision Positioning Table and Table 13 shows the specifications of these sensors. Tables 14 and 15 show the specifications of connectors.

Table 13 Types of sensors

Sensor		CW limit	CCW limit	Pre-origin	Origin
Table type					
TS • CT ⁽¹⁾	55/55	Mechanical switch	Mechanical switch	Proximity sensor	Photo sensor
	Other types	Photo sensor	Photo sensor	Photo sensor	Photo sensor ⁽²⁾

Note⁽¹⁾ : Specify sensor installation by the identification number.

⁽²⁾ : When an AC servo motor is used, the origin sensor is not attached. Use the C-phase or Z-phase signal of the encoder.

Table 14 Specifications of sensors

Item \ Sensor	Photo sensor	Proximity sensor	
		Limit and pre-origin	Origin
Power supply voltage	DC5~24V ±10%	DC12~24V ±10%	
Current consumption	30mA or less	10mA or less	
Output	Open collector • Maximum current : 100 mA • Applied voltage : 30 V DC or less • Residual voltage : 1.0 V or less at 100 mA in-flow current 0.4 V or less at 16 mA in-flow current		
Actuation	When lighting : ON	When approaching : OFF	When approaching : ON
Indicator	Red LED	Red LED	
Circuit diagram			

Table 15 Specifications of connectors for TS

Pin No.	Signal name	Connector used (manufactured by AMP)	
		Sensor side	Mating side
1	Origin	Cap housing 172160-1	Plug housing 172168-1
2	Pre-origin		
3	CW limit		
4	CCW limit		
5	Power supply	Contactor 170365-1	Contactor 170363-1
6	GND		

Table 16 Specifications of connectors for CT

Pin No.	Signal name	Connector used (manufactured by AMP)	
		Sensor side	Mating side
1	X axis Origin	Cap housing 172160-1	Plug housing 172170-1
2	X axis Pre-origin		
3	X axis CW limit		
4	X axis CCW limit		
5	Y axis Origin	Contactor 170363-1	Contactor 170365-1
6	Y axis Pre-origin		
7	Y axis CW limit		
8	Y axis CCW limit		
9	NC		
10	NC		
11	Power supply		
12	GND		

Remark : Prepare mating-side connectors at the customer side.

Table 17 Sensor timing chart for TS (single-axis specification)

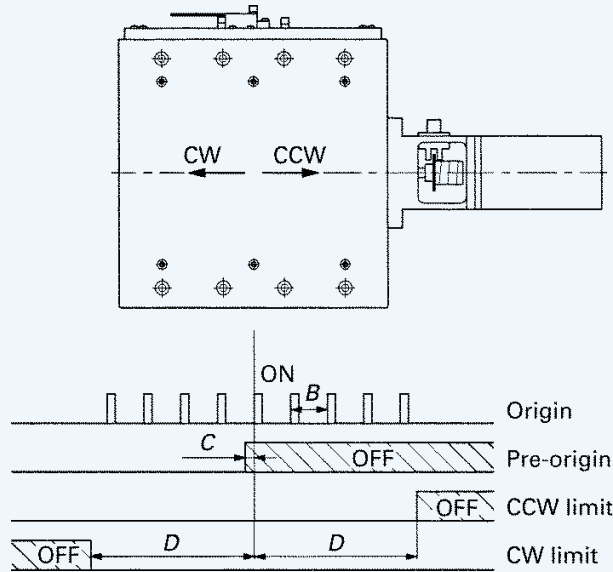

unit : mm

Table size	Ball screw lead	B	C	D
TS 55/ 55	1	1	0.7	7.5
TS 75/ 75	1	1	0.7	12.5
TS125/125	1	1	0.7	25
	2	2	1.5	
TS125/220	5	5	3	60
	2	2	1.5	
TS220/220	5	5	3	60
	2	2	1.5	
TS220/310	5	5	3	90
	2	2	1.5	
TS260/350	5	5	3	125
	2	2	1.5	

Remark 1 : Specify sensor installation by the identification number.

2 : When an AC servo motor is selected, the origin sensor is not attached. Use the C-phase or Z-phase signal of the encoder.

Table 18 Sensor timing chart for CT (two-axis specification)

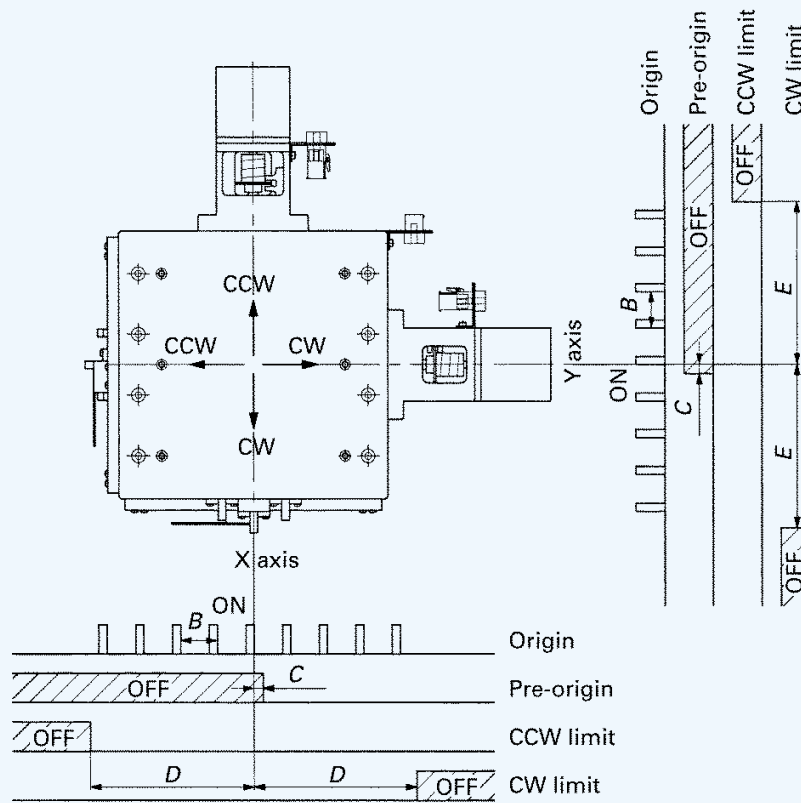

unit : mm

Table size	Ball screw lead	B	C	D	E
CT 55/ 55	1	1	0.7	7.5	7.5
CT 75/ 75	1	1	0.7	12.5	12.5
CT125/125	1	1	0.7	25	25
	2	2	1.5		
CT220/220	5	5	3	60	60
	2	2	1.5		
CT260/350	5	5	3	75	125
	2	2	1.5		
CT350/350	5	5	3	125	125
	2	2	1.5		

Remark 1 : Specify sensor installation by the identification number.

2 : When an AC servo motor is selected, the origin sensor is not attached. Use the C-phase or Z-phase signal of the encoder.

System Configuration

Table 19 System configuration using TS (single-axis specification) with AC servo motor [when using a control unit]

Table size	With or without brake	Motor code	Control unit			
			Main body	Teaching box	Motor cord	Limit/encoder cord
TS125/125 TS125/220 TS220/220	Without brake	A1, A2	NCD160G-A2006	TAE1050-TB	TAE2065-AM03 (TAE2072-AM03)	TAE2066-AEL03 (TAE2073-AEL03)
		M1, M2				TAE2067-AEL03 (TAE2074-AEL03)
TS220/310 TS260/350	With brake	A1B, A2B	NCD160G-A2006 TAE1049-BK (1)	TAE1050-TB	TAE2070-AMB03 (TAE2077-AMB03)	TAE2066-AEL03 (TAE2073-AEL03)
		M1B, M2B				TAE2071-AMB03 (TAE2078-AMB03)

Note(1) : Brake regenerative unit type. It is connected to the driver main unit.

Remark 1 : The cords in () have high bending resistance.

2 : The standard cord length is 3 m.

Table 20 System configuration using TS (single-axis specification) with AC servo motor [when using a driver plus a programmable controller]

Table size	With or without brake	Motor code	Model numbers of applicable electric devices						
			Driver			Programmable controller			
			Main body	Motor cord	Encoder cord	Main body	Teaching box	Pulse cord	Limit cord
TS125/125 TS125/220 TS220/220 TS220/310	Without brake	A1	TDA 1-1004	TAE2052-AM03 (TAE2036-AM03)	TAE2054-AE03 (TAE2038-AE03)	CTN120G	TAE1005-TB	TAE1022-LD03	
						CTN130G	TAE1016-TB	TAE1012-PC	TAE1042-LC03
						CTN140G	TAE1025-TB	TAE1030-PC	TAE1027-LCA03
						CTN150S	TAE1048-TB	TAE1022-LD03	
	With brake	A1B	TDA 1-1004BK	TAE2053-AMB03 (TAE2037-AMB03)		CTN120G	TAE1005-TB	TAE1022-LD03	
						CTN130G	TAE1016-TB	TAE1012-PC	TAE1042-LC03
						CTN140G	TAE1025-TB	TAE1030-PC	TAE1027-LCA03
						CTN150S	TAE1048-TB	TAE1022-LD03	
TS260/350	Without brake	A2	TDA 1-2004	TAE2052-AM03 (TAE2036-AM03)	TAE2054-AE03 (TAE2038-AE03)	CTN120G	TAE1005-TB	TAE1022-LD03	
						CTN130G	TAE1016-TB	TAE1012-PC	TAE1042-LC03
						CTN140G	TAE1025-TB	TAE1030-PC	TAE1027-LCA03
						CTN150S	TAE1048-TB	TAE1022-LD03	
	With brake	A2B	TDA 1-2004BK	TAE2053-AMB03 (TAE2037-AMB03)		CTN120G	TAE1005-TB	TAE1022-LD03	
						CTN130G	TAE1016-TB	TAE1012-PC	TAE1042-LC03
						CTN140G	TAE1025-TB	TAE1030-PC	TAE1027-LCA03
						CTN150S	TAE1048-TB	TAE1022-LD03	

Remark 1 : The cord in () have high bending resistance.

2 : The standard length of the motor cord, encoder cord, and limit cord are all 3 m. The pulse cord is 1.5 m long.

Table 21 System configuration using TS (single-axis specification) with stepping motor

Table size	With or without brake	Motor code	Model numbers of applicable electric devices					
			Driver		Programmable controller			
			Main body	Motor cord	Main body	Teaching box	Pulse cord	Limit cord
TS 55/ 55 TS 75/ 75	Without brake	S2	TDS1-5071	TAE2055-SMC03 (TAE2057-SNC03)	CTN120G	TAE1005-TB	TAE1056-LD03	
					CTN130G	TAE1016-TB	TAE1023-PC	TAE1042-LC03
					CTN140G	TAE1025-TB	TAE1026-PCA	TAE1027-LCA03
					CTN150S	TAE1048-TB	TAE1056-LD03	
			TDS1-5145	TAE2045-SML3 (TAE2059-SNL03)	CTN120G	TAE1005-TB	TAE1022-LD03	
					CTN130G	TAE1016-TB	TAE1012-PC	TAE1042-LC03
					CTN140G	TAE1025-TB	TAE1030-PC	TAE1027-LCA03
					CTN150S	TAE1048-TB	TAE1022-LD03	
TS125/125 TS125/220 TS220/220 TS220/310	Without brake	K4 K5	TDS1-5071	TAE2055-SMC03 (TAE2057-SNC03)	CTN120G	TAE1005-TB	TAE1056-LD03	
					CTN130G	TAE1016-TB	TAE1023-PC	TAE1042-LC03
					CTN140G	TAE1025-TB	TAE1026-PCA	TAE1027-LCA03
					CTN150S	TAE1048-TB	TAE1056-LD03	
			TDS1-5145	TAE2045-SML3 (TAE2059-SNL03)	CTN120G	TAE1005-TB	TAE1022-LD03	
					CTN130G	TAE1016-TB	TAE1012-PC	TAE1042-LC03
					CTN140G	TAE1025-TB	TAE1030-PC	TAE1027-LCA03
					CTN150S	TAE1048-TB	TAE1022-LD03	
	With brake	K4B K5B	TDS1-5145BK	TAE2061-SMBL3 (TAE2062-SNBL03)	CTN120G	TAE1005-TB	TAE1022-LD03	
					CTN130G	TAE1016-TB	TAE1012-PC	TAE1042-LC03
					CTN140G	TAE1025-TB	TAE1030-PC	TAE1027-LCA03
					CTN150S	TAE1048-TB	TAE1022-LD03	
TS260/350	Without brake	K7	TDS1-5145	TAE2045-SML3 (TAE2059-SNL03)	CTN120G	TAE1005-TB	TAE1022-LD03	
					CTN130G	TAE1016-TB	TAE1012-PC	TAE1042-LC03
					CTN140G	TAE1025-TB	TAE1030-PC	TAE1027-LCA03
					CTN150S	TAE1048-TB	TAE1022-LD03	
	With brake	K7B	TDS1-5145BK	TAE2061-SMBL3 (TAE2062-SNBL03)	CTN120G	TAE1005-TB	TAE1022-LD03	
					CTN130G	TAE1016-TB	TAE1012-PC	TAE1042-LC03
					CTN140G	TAE1025-TB	TAE1030-PC	TAE1027-LCA03
					CTN150S	TAE1048-TB	TAE1022-LD03	

Remark 1 : The cord in () have high bending resistance.

2 : The standard length of the motor cord and limit cord are all 3 m. The pulse cord is 1.5 m long.

Table 22 System configuration using CT (two-axis specification) with AC servo motor [when using a driver plus a programmable controller]

Table size	With or without brake	Motor code	Model numbers of applicable electric devices						
			Driver			Programmable controller			
			Main body	Motor cord	Encoder cord	Main body	Teaching box	Pulse cord	Limit cord
CT125/125 CT220/220	Without brake	A1	TDA 1-1004 2 units	TAE2052-AM03 (TAE2036-AM03) 2 cords	TAE2054- AE03 (TAE2038- AE03) 2 cords	CTN220G	TAE1005-TB	TAE1062-LDY03	
						CTN230G	TAE1016-TB	TAE1013-PCY	TAE1063-LC03
						CTN240G	TAE1025-TB	TAE1031-PCY	TAE1064-LCA03
	With brake	A1B	TDA 1-1004 + TDA 1-1004BK	TAE2052-AM03 (TAE2036-AM03) + TAE2053-AMB03 (TAE2037-AMB03)		CTN220G	TAE1005-TB	TAE1062-LDY03	
						CTN230G	TAE1016-TB	TAE1013-PCY	TAE1063-LC03
						CTN240G	TAE1025-TB	TAE1031-PCY	TAE1064-LCA03
CT260/350 CT350/350	Without brake	A2	TDA 1-2004 2 units	TAE2052-AM03 (TAE2036-AM03) 2 cords	TAE2054- AE03 (TAE2038- AE03) 2 cords	CTN220G	TAE1005-TB	TAE1062-LDY03	
						CTN230G	TAE1016-TB	TAE1013-PCY	TAE1063-LC03
						CTN240G	TAE1025-TB	TAE1031-PCY	TAE1064-LCA03
	With brake	A2B	TDA 1-2004 + TDA 1-2004BK	TAE2052-AM03 (TAE2036-AM03) + TAE2053-AMB03 (TAE2037-AMB03)		CTN220G	TAE1005-TB	TAE1062-LDY03	
						CTN230G	TAE1016-TB	TAE1013-PCY	TAE1063-LC03
						CTN240G	TAE1025-TB	TAE1031-PCY	TAE1064-LCA03

Remark 1 : The cords in () have high bending resistance.

2 : The standard length of the motor cord, encoder cord, and limit cord are all 3 m. The pulse cord is 1.5 m long.

3 : In tables with brake, a motor with brake is provided only for the Y axis.

Table 23 System configuration using CT (two-axis specification) with stepping motor

Table size	With or without brake	Motor code	Model numbers of applicable electric devices							
			Driver		Programmable controller					
			Main body	Motor cord	Main body	Teaching box	Pulse cord	Limit cord		
CT 55/ 55 CT 75/ 75	Without brake	S2	TDS1-5071 2 units	TAE2055-SMC03 (TAE2057-SNC03) 2 cords	CTN220G	TAE1005-TB	TAE1065-LDY03			
					CTN230G	TAE1016-TB	TAE1057-PCY	TAE1063-LC03		
					CTN240G	TAE1025-TB	TAE1028-PCAY	TAE1064-LCA03		
			TDS2-5145	TAE2045-SML03 (TAE2059-SNL03) 2 cords	CTN220G	TAE1005-TB	TAE1061-LD03			
					CTN230G	TAE1016-TB	TAE1012-PC	TAE1063-LC03		
					CTN240G	TAE1025-TB	TAE1030-PC	TAE1064-LCA03		
CT125/125 CT220/220	Without brake	K4 K5	TDS1-5071 2 units	TAE2055-SMC03 (TAE2057-SNC03) 2 cords	CTN220G	TAE1005-TB	TAE1065-LDY03			
					CTN230G	TAE1016-TB	TAE1057-PCY	TAE1063-LC03		
					CTN240G	TAE1025-TB	TAE1028-PCAY	TAE1064-LCA03		
			TDS2-5145	TAE2045-SML03 (TAE2059-SNL03) 2 cords	CTN220G	TAE1005-TB	TAE1061-LD03			
					CTN230G	TAE1016-TB	TAE1012-PC	TAE1063-LC03		
					CTN240G	TAE1025-TB	TAE1030-PC	TAE1064-LCA03		
	With brake	K4B K5B	TDS2-5145BK	TAE2045-SML03 (TAE2059-SNL03) + TAE2061-SMBL03 (TAE2062-SNBL03)	CTN220G	TAE1005-TB	TAE1061-LD03			
					CTN230G	TAE1016-TB	TAE1012-PC	TAE1063-LC03		
					CTN240G	TAE1025-TB	TAE1030-PC	TAE1064-LCA03		
					TDS2-5145	TAE2045-SML03 (TAE2059-SNL03) 2 cords	CTN220G	TAE1005-TB	TAE1061-LD03	
							CTN230G	TAE1016-TB	TAE1012-PC	TAE1063-LC03
							CTN240G	TAE1025-TB	TAE1030-PC	TAE1064-LCA03
CT260/350 CT350/350	Without brake	K7	TDS2-5145	TAE2045-SML03 (TAE2059-SNL03) 2 cords	CTN220G	TAE1005-TB	TAE1061-LD03			
					CTN230G	TAE1016-TB	TAE1012-PC	TAE1063-LC03		
					CTN240G	TAE1025-TB	TAE1030-PC	TAE1064-LCA03		
	With brake	K7B	TDS2-5145BK	TAE2045-SML03 (TAE2059-SNL03) + TAE2061-SMBL03 (TAE2062-SNBL03)	CTN220G	TAE1005-TB	TAE1061-LD03			
					CTN230G	TAE1016-TB	TAE1012-PC	TAE1063-LC03		
					CTN240G	TAE1025-TB	TAE1030-PC	TAE1064-LCA03		

Remark 1 : The cords in () have high bending resistance.

2 : The standard length of the motor cord and limit cord are all 3 m. The pulse cord is 1.5 m long.

3 : In tables with brake, a motor with brake is provided only for the Y axis.

TS

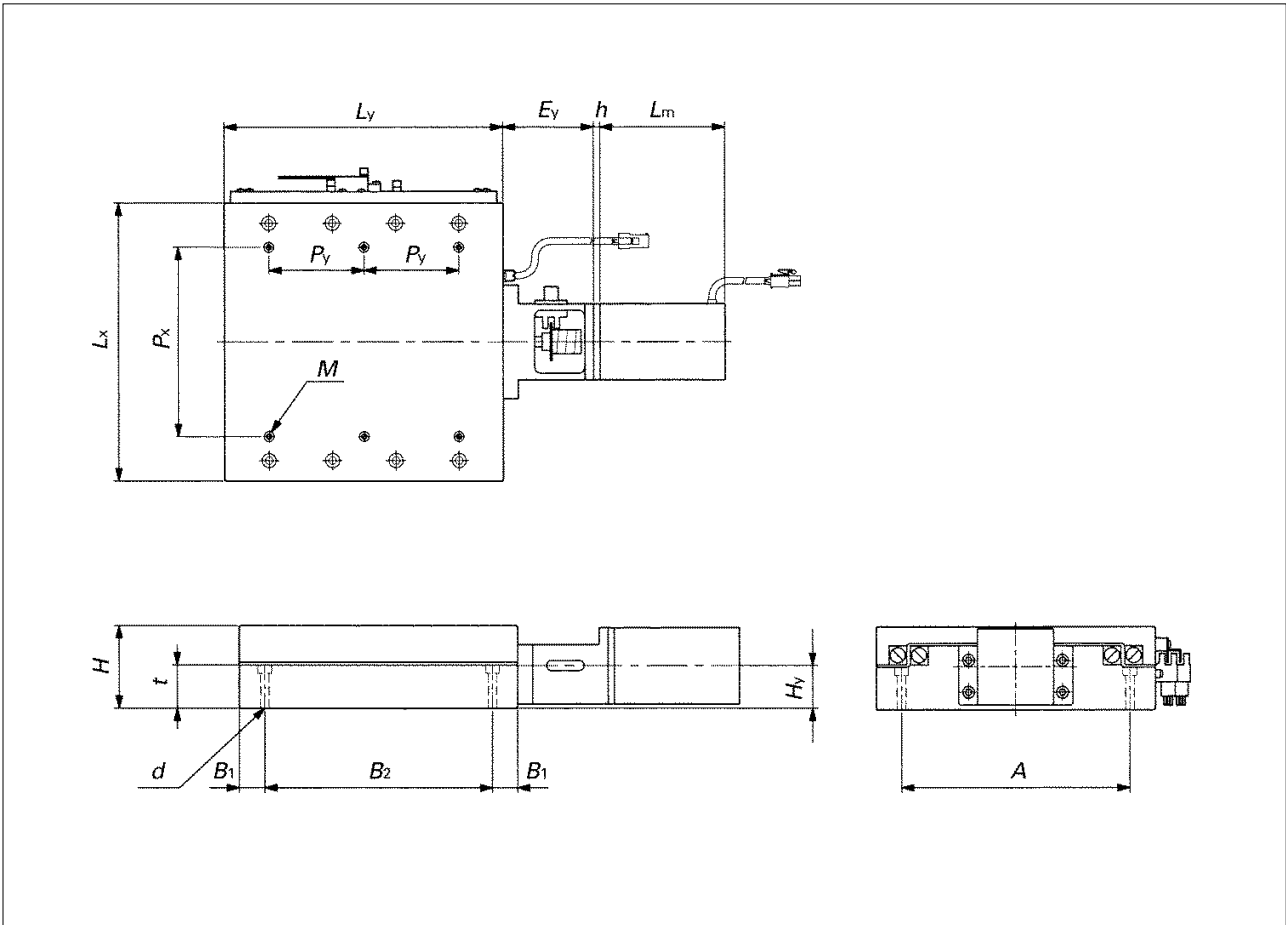

Remark : The figure shows a table with sensors.

●TAE9012-BE

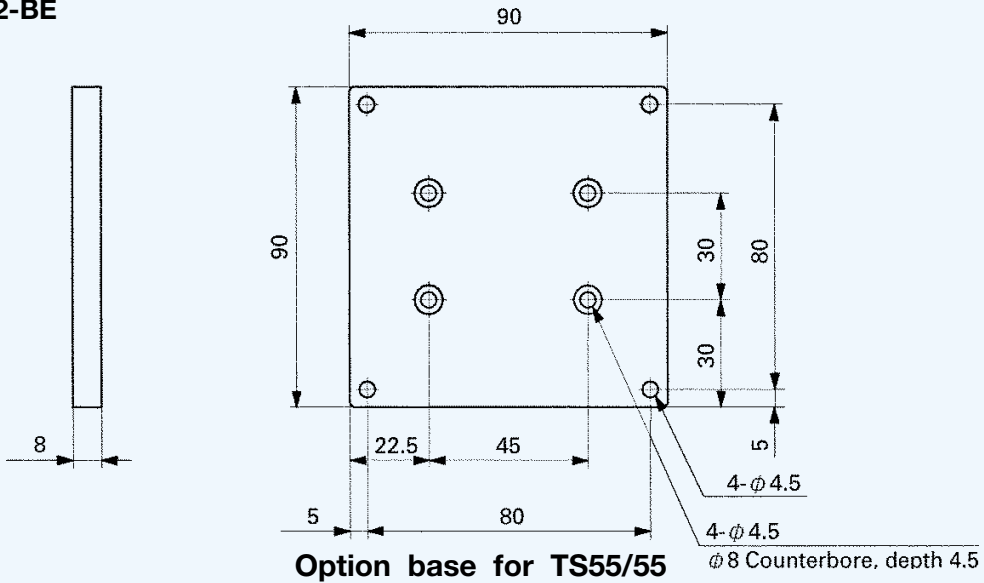

Dimensions of table

unit : mm

Model number	Dimensions of table			Stroke length	Bracket length E_y	Shaft center height H_y
	L_x	L_y	H			
TS 55/ 55	55	55	35.5	15	40	20
TS 75/ 75	75	75	40	25	40	20
TS125/125⁽²⁾	125	125	60	50	52	31.5
TS125/220⁽²⁾	125	220	60	120	72	31.5
TS220/220	220	220	65	120	72	33.5
TS220/310	220	310	70	180	110	33.5
TS260/350	260	350	100	250	120	47.5

Model number	Mounting bolt			Mounting dimensions of bed					Mass ⁽¹⁾ (Ref.) kg
	M	P_x	P_y	d	t	A	B_1	B_2	
TS 55/ 55	6-M3 depth 4.5	30	17.5	4-M4 depth 8	26	30	5	45	0.72
TS 75/ 75	6-M4 depth 5.5	40	30	For 4-M4	24	62	7.5	60	1.6
TS125/125⁽²⁾	6-M5 depth10	70	50	For 4-M5	35	100	15	95	7.3
TS125/220⁽²⁾	6-M5 depth10	70	75	For 4-M5	35	100	20	180	11.0
TS220/220	6-M6 depth12	150	75	For 4-M6	34	180	20	180	15.7
TS220/310	6-M6 depth12	150	100	For 4-M6	35	180	50	210	26.5
TS260/350	6-M6 depth12	150	125	For 4-M8	54	215	50	250	47.5

Note⁽¹⁾ : The mass of the motor is not included.

⁽²⁾ : The motor bracket is 1.5 mm higher than the top surface of the table.

Dimensions of motor

unit : mm

Table size	Motor type	With or without brake	Motor code	h	L_m
TS 55/ 55	Stepping motor	Without brake	S2	—	45
TS 75/ 75	Stepping motor	Without brake	S2	—	45
TS125/125	AC servo motor	Without brake	A1	5	94.5
			M1	5	103
		With brake	A1B	5	135
			M1B	5	135
	Stepping motor	Without brake	K4	5	46.5
		With brake	K4B	5	88.5
TS125/220 TS220/220 TS220/310	AC servo motor	Without brake	A1	5	94.5
			M1	5	103
		With brake	A1B	5	135
			M1B	5	135
	Stepping motor	Without brake	K5	5	57.5
		With brake	K5B	5	99.5
TS260/350	AC servo motor	Without brake	A2	—	96.5
			M2	—	95
		With brake	A2B	—	136
			M2B	—	128
	Stepping motor	Without brake	K7	10	66
		With brake	K7B	10	119

1N=0.102kgf=0.2248lbs.
1mm=0.03937inch

CT

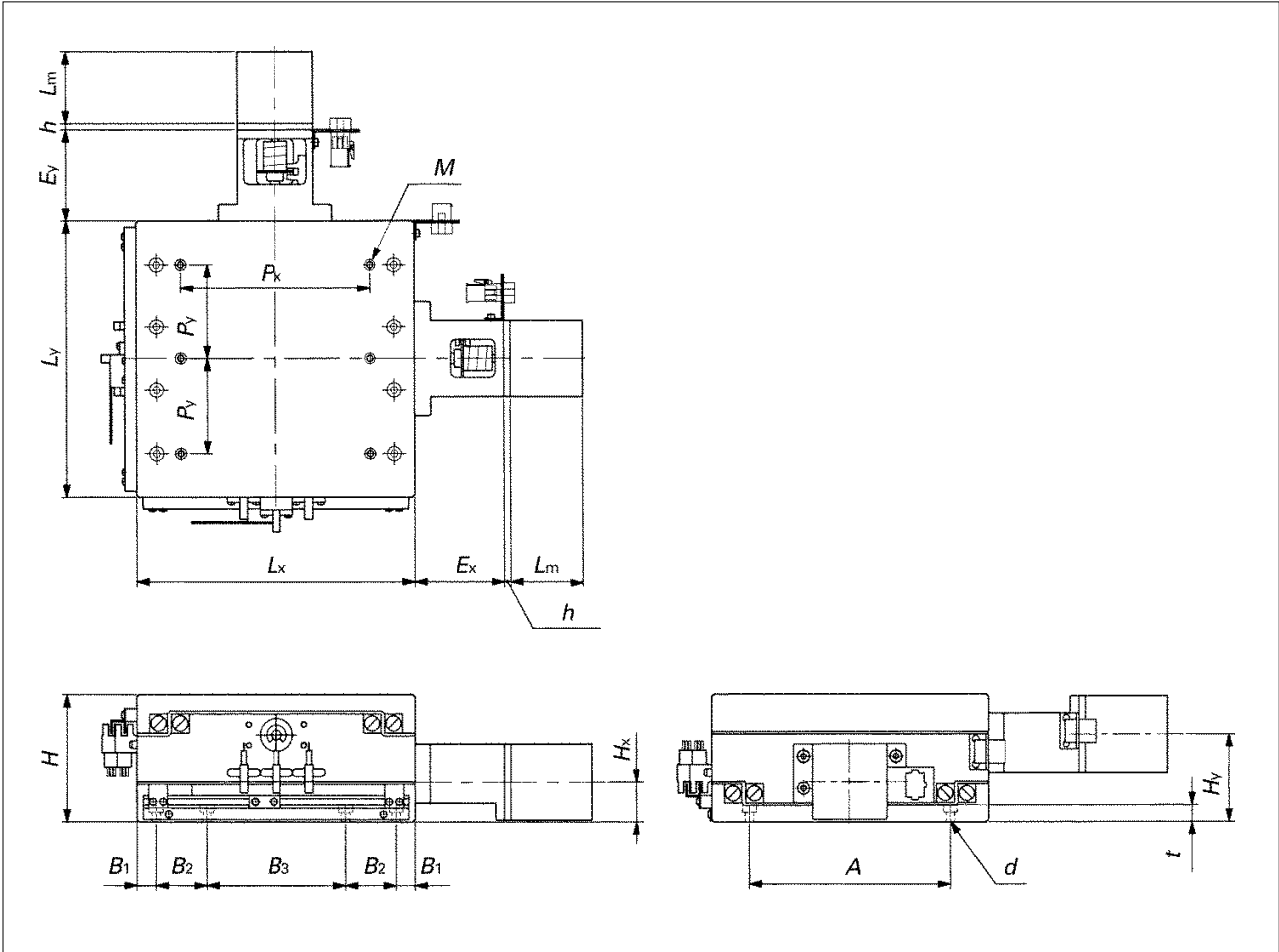

Remark : The figure shows a table with sensors.

● **TAE9012-BE**

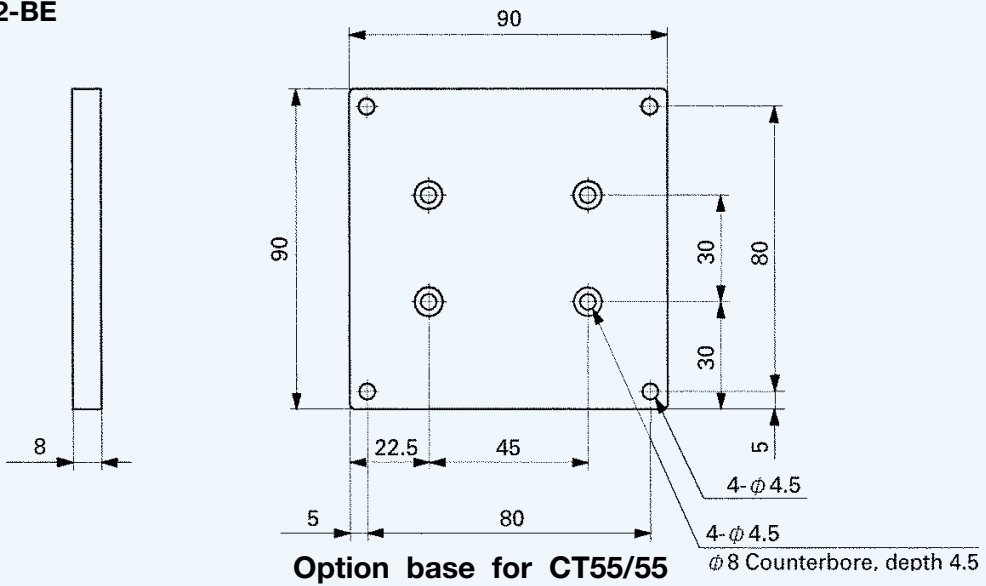

Dimensions of table

unit : mm

Model number	Dimensions of table			Stroke length		Bracket length		Shaft center height		
	L_x	L_y	H	X axis	Y axis	E_x	E_y	H_x	H_y	
CT 55/ 55⁽²⁾	55	55	45	15	15	40	40	15.5	29.5	
CT 75/ 75	75	75	55	25	25	40	40	20	35	
CT125/125⁽³⁾	125	125	85	50	50	52	52	30.5	56.5	
CT220/220	220	220	100	120	120	72	72	31.5	68.5	
CT260/350	260	350	150	150	250	100	120	52.5	97.5	
CT350/350	350	350	150	250	250	120	120	52.5	97.5	
Model number	Mounting bolt			Mounting dimensions of bed						Mass ⁽¹⁾ (Ref.) kg
	M	P_x	P_y	d	t	A	B_1	B_2	B_3	
CT 55/ 55⁽²⁾	6-M3 depth 4.5	30	17.5	4-M4 depth 4.5	4.5	30	5	—	45	1.7
CT 75/ 75	6-M4 depth 5.5	40	30	4-M4 depth 5.5	9	40	7.5	—	60	2.0
CT125/125⁽³⁾	6-M5 depth10	70	50	For 4-M5	14	80	15	—	95	7.5
CT220/220	6-M6 depth12	150	75	For 8-M6	14	160	15	40	110	19.4
CT260/350	6-M6 depth12	150	125	For 8-M8	29	270	15	55	120	66.0
CT350/350	6-M6 depth12	250	125	For 8-M8	29	270	15	100	120	76.7

Note⁽¹⁾ : The mass of the motor is not included.

⁽²⁾ : The X-axis motor bracket is 3.5 mm lower than the bottom surface of the table and the Y-axis motor bracket is 3.5 mm higher than the top surface of the table.

⁽³⁾ : The Y-axis motor bracket is 1.5 mm higher than the top surface of the table.

Dimensions of motor

unit : mm

Table size	Motor type	With or without brake	Motor code	h	L_m
CT 55/ 55 CT 75/ 75	Stepping motor	Without brake	S2	—	45
			CT125/125	AC servo motor	Without brake
With brake	M1	5			103
	Stepping motor	A1B		5	135
M1B		5		135	
CT220/220	AC servo motor	Without brake	K4	5	46.5
		With brake	K4B	5	88.5
	Stepping motor		Without brake	A1	5
		With brake	M1	5	103
			A1B	5	135
		M1B	5	135	
CT260/350 CT350/350	AC servo motor	Without brake	K5	5	57.5
		With brake	K5B	5	99.5
	Stepping motor		Without brake	A2	—
		With brake	M2	—	95
Stepping motor	A2B		—	136	
	M2B	—	128		
Stepping motor	Without brake	K7	10	66	
	With brake	K7B	10	119	

Remark : In the table with brake, a motor with brake is provided only for the Y axis.

Mounting

■ Mounting surface accuracy

The accuracy and performance of Precision Positioning Table are affected by the accuracy of the mating mounting surface. Accordingly, mounting surface finish accuracy must be examined, considering the operating conditions such as required motion performance and positioning accuracy.

Table 24 Mounting surface accuracy unit : μm

Type	Flatness of mounting surface
TS · CT	10

■ Tightening torque of mounting bolts

The standard torque values for fixing Precision Positioning Table are shown in Table 23. When machines or equipment are subjected to frequent rapid acceleration or deceleration, or moment load, the bolts should be tightened with a torque 1.3 times higher than the standard torque values shown in the table. When high accuracy is required and vibration or shock is not present, it is recommended to tighten the bolts with a lower torque than the values shown in the table and use a bonding agent to prevent loosening of the bolts.

Table 25 Tightening torque of bolts

unit : N·m

Nominal bolt size	Female thread material		
	Iron	Aluminum alloy	
		With Helicert	
M 3×0.5	1.7	Approx. 60% of the value for iron	Approx. 80% of the value for iron
M 4×0.7	4.0		
M 5×0.8	7.9		
M 6×1	13.3		
M 8×1.25	32.0		
M10×1.5	62.7		

Precautions for Use

■Cautions on safety

- Be sure to connect the ground terminal (class 3 grounding). An electric shock or fire will be caused.
- Do not operate the product at any power supply voltage other than that shown on the product. A fire or failure will be caused.
- Do not touch electric devices with wet hands. An electric shock will be caused.
- Do not bend by force, twist, pull, or heat the cord, or put a heavy material on it. An electric shock or fire will be caused.
- Do not put fingers, etc. in the opening during table operation. An injury will be caused.
- Do not touch the moving portion during table operation. An injury will be caused.
- When removing the cover of the electric device section, be sure to turn off the power supply and pull out the power plug beforehand. An electric shock will be caused.
- Do not touch the terminal for 5 minutes after turning off the power supply. The residual voltage may cause an electric shock.
- When connecting or disconnecting the connection terminal, be sure to turn off the power supply and pull out the power plug beforehand. An electric shock or fire will be caused.

■Cautions on safety

- Precision Positioning Table is a precision machine. Therefore, handle it with great care and do not apply an excessive load or strong impact on it to avoid accuracy loss or part damage.
- Make sure that the mounting base surface is free from dirt and harmful protuberances.
- The linear motion rolling guide and ball screw assembled in Precision Positioning Table is coated with grease. So make sure to keep dirt or any foreign matter from entering into the table. If dirt or any foreign matter had entered inside, remove the dirty grease completely and then apply clean grease again.
- The re-lubrication interval for Precision Positioning Table differs depending on the operating conditions. Generally, it is recommended to remove old grease and apply clean grease at an interval of 6 months, or for machines that are put into frequent reciprocating motions of long strokes, at an interval of 3 months.
- Precision Positioning Table is machined, assembled, and adjusted with high precision. Therefore, never disassemble or remodel the table.

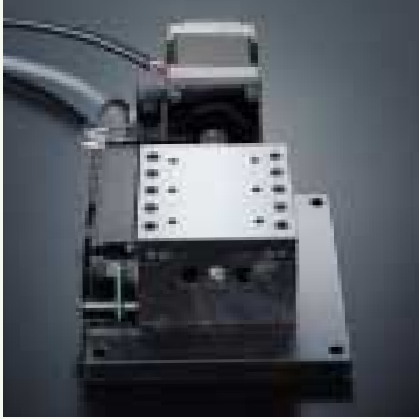

NIPPON THOMPSON CO., LTD.

Although all data in this catalog has been carefully compiled to make the information as complete as possible, NIPPON THOMPSON CO., LTD. shall not be liable for any damages whatsoever, direct or indirect, based upon any information in this catalog. NIPPON THOMPSON CO., LTD. makes no warranty, either express or implied, including the implied warranty of merchantability or fitness for a particular purpose.