

## CBX 2 & 3 AXIS DIGITAL READOUT PACKAGES



**SERIES 508:**

Digital Position Readout for your mill, mill drill or lathe\* (\*radius/diameter switch)

Scales can easily be shortened by user.

- 1 - 16\*\* inch scale
- 1 - 48\*\* inch scale
- 1 - 2 axis CBX Digital Display Unit
- 0.0005 inch resolution INC./ABS. Mode
- Presets
- Reversible Count Direction
- Includes all mounting hardware and cables.

**2-Axis Order No. 5080005**

Price:

**3-Axis Order No. 5080007**

Price:



**5080005**

3-Axis Packages include an extra 16\*\*\* scale and a 3 axis CBX Digital Display Unit



**5080007**

## DIGITAL READOUT QUILL KITS



**SERIES 725:**

Digital Z-Axis Readout for Bridgeport® Type Mills



- Can be mounted on almost any surface.
- SPC Output • Resolution .0005" / 0.01mm
- Accuracy: ± .001" / 0.03mm
- LCD unit displays "E-05" for movement error.
- Includes 2 mounting brackets and EZ mount bracket kit.
- Offers precise linear measurement capabilities.
- One SR44 1.5V battery is supplied.
- Sliding unit can be moved 40" per second.

Range	LCD Horizontal		LCD Vertical	
	Order No.	Price	Order No.	Price
6"/150mm	7250061		7250062	
8"/200mm	7250081		7250082	
12"/300mm	7250121		8250122	
18"/450mm	7250181		8250182	

## 5-FIGURE DIGIT COUNTER

**SERIES 257:**



Counts to 99,999. Reset knob for quick "zero" setting. 4 holes in base for easy and rigid mounting. Counter is activated by a 45° movement of the arm. Unit comes with a spring on the lever arm for attaching to machine.

**Order No. 1735005**

Price:



## QUILL KIT

**SERIES 572:**

Easy Installation Fits Most Vertical Knee Mills

**FEATURES:**

- Easy to read LCD with resolution of .0005"/0.01mm
- Push button controls for inch/mm, Zero-Set and On/Off
- Powered by a single SR-44 Battery which lasts about 1 year with normal use
- SPC Output for data transmission to Data Processors or LED Remote Display Box



Kit mounted on a vertical mill

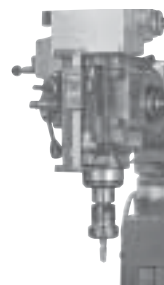

Digimatic Quill Kit complete with brackets & scale for Bridgeport® Type machines.

**Order No. 053-906**

Price:

## ELECTRONIC COUNTER & ELECTRONIC TIME COUNTER



**SERIES 257:**

Super compact, large LCD display, long battery life, panel mount, reset.

- Connection: Lead wires, wire-wrap terminals.
- Counter has 30 cycle per second counting speed. Counts to 99,999,999.
- Time counter - elapsed time up to 99,999.99 hours.



**Electronic Counter Order No. 2575000**

Price:

**Electronic Time Counter Order No. 2577500**

Price:

## PRO/CALC® - MATERIAL DIRECTORY & SPINDLE SPEED CALCULATOR



**SERIES 508:**

Throw out those oil stained charts!

Pro/Calc® takes the guess work out of the question "what RPM should I be using?"

The Pro/Calc® a hand held battery operated reference directory that requires no mathematical computation

It is as easy as 1-2-3

Simply Select:

- 1- Material to be machined (80% of the most used metals)
  - 2- Operation: cut-off, form tool, end mills, counterbore, turning, fly-cutting, face milling, tapping, reaming, and drilling.
  - 3- Diameter of tool.
- The correct RPM will automatically be displayed. (Also displayed are heat treated materials and tap drill sizes.)**



**Order No. 6000008**

Price:

While we show the most popular **Mitutoyo** Digital readout systems, we can supply their entire range; please inquire.

# NEW MITUTOYO AOS - DRO SYSTEM KA COUNTER WITH AT - 715 MAGNETIC SCALES



SERIES:

## KA Counter

- Selectable Resolutions (.00005, .0001, .0002, .0005") allows choice according to the tolerance requirements of the work being performed
- Bolt Circle Calculation (eliminates need to use trigonometry to calculate hole positions)
- Diameter Mode (doubles reading on cross axis of lathe)
- Tool Offsets (stores datum points for 10 tools which eliminates need to re-zero after tool changes)
- Connectable with AT-715 Magnetic scales or AT-100 series Glass scales (allows use of magnetic and/or glass scales for different applications)
- RS-232 Output (optional) allows data capture and storage on remote computer
- Touch Probe (optional) allows automatic edge detection for zeroing part



## AT-715 Magnetic Scales



- Fully submersible in coolant (coolant never effects scale position reading)
- +/- .00012" accuracy over ft./12 in.
- True Absolute (no battery backup - means position information is never lost, even after power interruption)
- Shock Resistant
- Reader Head mounted on saddle guide for easy installation (alignment not as critical)

## ABS AOS DRO Linear Scale System

### SPECIFICATIONS

#### AT715 Linear scale

Detection system	Electromagnetic induction system (3 tracks, absolute AOS)	
Resolution	0.005 mm / 0.002 mm / 0.001 mm (Changeable by parameter setting) .0005 inch / .0002 inch / .0001 inch / .00005 inch (Changeable by parameter setting)	
Dimensions	Height	1.43" / 36.5mm
	Width	.87" / 22mm
	Length	varies according to travel length specified/ordered
Effective range	3.94" x 70.87"/100 ~ 1800 mm	
Signal output	Mitutoyo original Serial format (can not connect to KL, KLL, KS, KC Counter)	
Accuracy	( 7 + 13L / 1000 )um [ L : Effective range (mm) ]	
Maximum response speed	50 m / min.	
CE marking	Corresponding to the regulations	

#### KA-Counter

Resolution	0.005 mm / 0.002 mm / 0.001 mm (Changeable by parameter setting) .0005 inch / .0002 inch / .0001 inch / .00005 inch (Changeable by parameter setting)
Readout	2-axis, 3-axis ( Using 2-axis counter for 1-axis requirement ) ( For lathes, using 3-axis counter with the parameter setting changed )
Display	Seven segment LED / 7 digit, 1 digit for coordinate number
Main function	Zero setting, Preset, Low digit OFF, 10 coordinate position memory, Bolt-Hole-Circle, mm / inch conversion, Counting direction setting, Resolution setting (Parameter setting), Diameter display, 1/2 calculation, Smoothing display, Tool offsets (Parameter setting)
Input	Automatic discrimination of scale connected ABS AOS DRO scale (AT715 and AT100 series) 2Vpp sine wave
Output	RS-232C interface ( Option )
CE marking	Corresponding to the regulations

# DIGITAL READOUT SYSTEMS

SERIES 3572:



## MAGNETIC ABS - AOS - DRO PACKAGE FOR MILLING SYSTEM

USING KA COUNTER AND AT715 SCALES

### 2 Axis, KA Counter Milling System

	Y Axis Travel			
	AT715-300 (12")	AT715-350 (14")	AT715-400 (16")	
	For Bridgeport #1	For Taiwan	For Lagun	For Taiwan
AT715-750 (30") Axis Travel	Package Number 174-173PM1	Package Number 174-173PM3	Package No.	Package No.
AT715-900 (36") Axis Travel	174-173PM2		174-173PM4	174-173PM5
AT715-1000 (40") Axis Travel		174-173PM6	174-173PM7	174-173PM8

**Package Includes:**

- KA Counter
- Brackets for Scales
- AT715 Linear Scales
- Display Arm Kit

Order No. 5720001

Price:

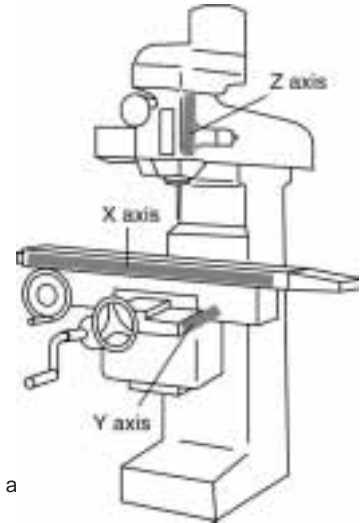

### 3 Axis, KA Counter Milling System (Z axis length 6")

	Y Axis Travel			
	AT715-300 (12")	AT715-350 (14")	AT715-400 (16")	
	For Bridgeport #1	For Taiwan	For Lagun	For Taiwan
AT715-750 (30") Axis Travel	Package Number 174-175PM1	Package Number 174-175PM3	Package No.	Package No.
AT715-900 (36") Axis Travel	174-175PM2		174-175PM4	174-175PM5
AT715-1000 (40") Axis Travel		174-175PM6	174-175PM7	174-175PM8

**Package Includes:**

- KA Counter
- Brackets for Scales
- AT715 Linear Scales/  
AT715-150mm (6") for Z a
- Display Arm Kit

Order No. 5720002

Price:

\* Specify "Package" number when ordering.

## LINEAR SCALE PACKAGES FOR LATHES

**Package Includes:**

- KA Counter Glass
- AT115, AT102 Linear Scale and Extension Cable.
- Bracket Kits
- Counter Stand
- Counter Tray

### 2 Axis, KA Counter Lathe System

Z Axis Travel	X Axis Travel		
	AT115-200 (8")	AT115-250 (10")	AT115-300 (12")
AT715-1000 (40")	Package Number 174-173PL3	Package Number 174-173PL4	-
AT715-1200 (48")		174-173PL6	-
AT715-1500 (60")		174-173PL 7	174-173PL29

Z-Axis Travel	Order No.	Price
1000	5720004	
1200, 1500	5720005	

\* Specify "Package" number when ordering.

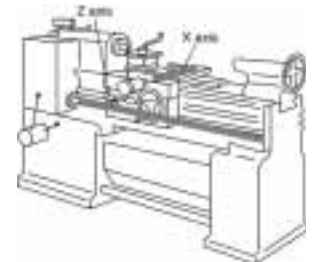

All other sizes available; please inquire

## AT100 SERIES - GLASS SCALE UNITS

### FEATURES

#### 1. Low-priced model AT115

The low-priced version of Mitutoyo Linear Scale AT115 series are available. The mounting dimensions of all the AT115 models are the same as those of the AT111 series. Most suitable for mounting on a milling machine or an XY table.

#### 2. Joint structure of detector

The ball joint structure is employed at the joint of the detector head and the slider (sensor unit) inside the scale. This structure prevents the slider movement from deviating from the normal moving directions when the detector head shifts to right and left, thus providing a normal scale reading and increasing flexibility in the scale installation. In addition, this structure is highly rigid and therefore has an excellent durability.

#### 3. Water-proof connector

A waterproof/splash-proof connector is used to enable separation of the signal cable. Thus, an installation and maintenance of the Linear Scale can be easily performed. (The signal cable in AT115 cannot be separated.)

#### 4. Conduit armored type signal cable

A waterproof/splash-proof connector is used to enable separation of the signal cable. Thus, an installation and maintenance of the Linear Scale can be easily performed. (The signal cable in AT115 cannot be separated.)

#### 5. Unique rubber-lip openings

The rubber-lip openings are shaped like the bottom of a ship that plows the water.

#### 6. Excellent splash and dust-proof rubber lip structure

The rubber lips are made of a strong, special urethane and wires are inserted in these lips to improve the splash-proofing and dust-proofing of the scale. (AT102 only)

## GLASS LINEAR SCALE PACKAGE FOR GRINDER SYSTEM

USING KA COUNTER AND AT115

### 2 Axis, KA Counter Grinder System

\* Specify "Package" number when ordering.

Vertical	Cross Side			
	AT115-150 (6")	AT115-200 (8")	AT115-250 (10")	AT115-300 (12")
AT115-300 (12")	Package Number 174-173PG1L	Package Number 174-173PG8L	Package Number -	Package Number -
AT115-350 (14")	174-173PG7L	174-173PG3L	174-173PG5L	
AT115-400 (16")		174-173PG4L	174-173PG13L	
AT115-450 (18")	174-173PG2L	174-173PG9L	174-173PG6L	174-173PG14L
AT115-500 (20")		174-173PG10L	174-173PG11L	174-173PG15L
AT115-600 (24")			174-173PG12L	174-173PG16L

**Package Includes:**

- KA Counter
- AT115 Glass Linear Scale / Magnetic Scale available at same price; please inquire
- Bracket Kits
- Display Arm Kit

Order No. 5720003

Price:

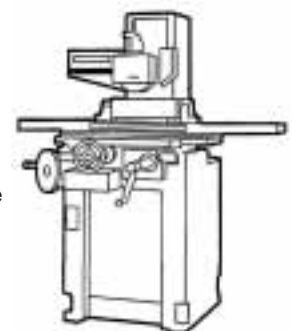

Many other packages available; please inquire.