

J-Type Plate Nuts (Screw type)

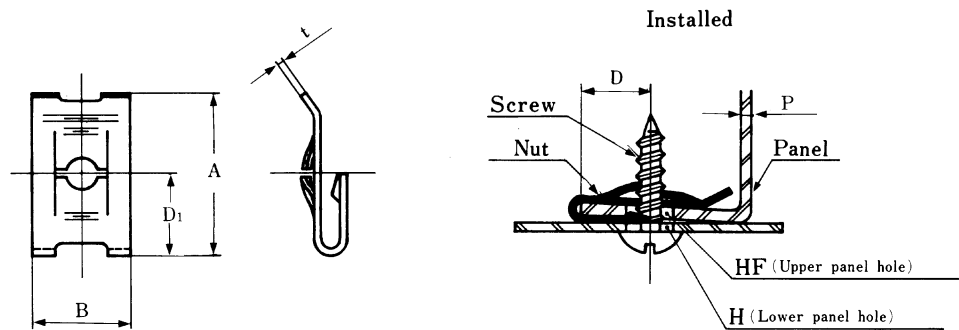

Unit : mm

Size-No.	Applicable screw see note 1	Nut dimension				Panel size					Hardness (HRC)
		A	B	D ₁	t	P		D	H	HF	
						Min.	Max.				
J S N-3001	M 3 × 0.5	18	11.2	9	0.3	0.6	1	7.5	4	5.5	
4001	M 4 × 0.7	20	12.7	10	0.4	0.7	1.2	8	5	7	
4003	M 4 - 18	20	12.7	10	0.6	0.8	1.2	8	5	7	39 ~ 47
5001	M 5 × 0.8	20	12.7	10	0.45	0.7	1.2	8	6	8	
5004	M 5 - 16	21.2	12.7	11.2	0.7	0.7	1.2	9	6	8	39 ~ 47
5003	M 5 - 12	22	12.7	12	0.7	2.5	3	9	6	8	39 ~ 47
6001	M 6 × 1	20	12.7	10	0.5	0.7	1.2	8	7.5	9.5	
6002	M 6 - 14	20	12.7	10	0.7	0.7	0.8	8	7.5	9.5	39 ~ 47

●Material=Carbon spring steel. Hardness=HRC40~50. Finish=Phosphate coating.

Note; 1. Applicable screw must be used tapping screw JIS B 1115.

2. Enquire special types of nut when you need other size or type.

U-Type Wide Panel Nuts(Screw type)

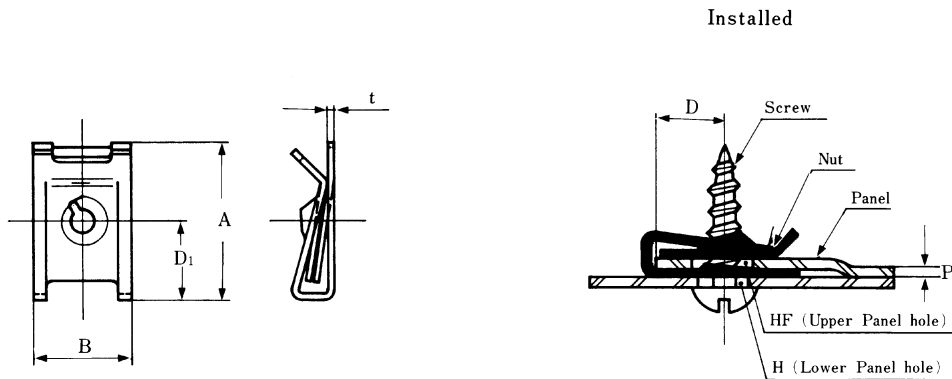

Unit : mm

Size-No.	Applicable screw see note 1	Nut dimension				Panel size					Remarks	Hardness (HRC)
		A	B	D ₁	t	P		D	H	HF		
						Min.	Max.					
W U S N-4039	M 4 - 18	21.6	12.7	10.1	0.6	0.7	2.5	8	5	7	Float	39 ~ 47
4044	M 4 - 18	16.6	13.5	8.6	0.6	0.6	2	7	5	6	Without float	
5022	M 5 - 16	21.7	12.7	10.2	0.7	0.7	2.5	8	6	8		39 ~ 47
5025	M 5 - 16	20.6	13.5	9.5	0.6	0.6	3.8	8	6	7	Without float	38 ~ 45
5029	M 5 - 16	21.7	12.7	10.2	0.7	2	3	8	6	7	Without float	39 ~ 47

●Material=Carbon spring steel. Hardness=HRC40~50. Finish=Phosphate coating.

Note; 1. Applicable screw must be used tapping screw JIS B 1115.

2. Enquire special types of nut when you need other size or type.