

RSV61

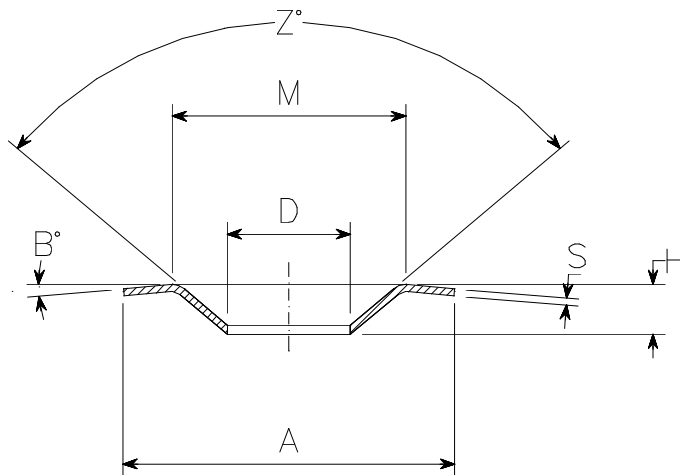

dimensions in mm.

P/N	A	B	D	H	M	S	Z	mass kg x 1000
RSV61-06	+0,5 -0,1	±1	+0,75 -0	ref	+0,25 -0	± 0,05	+3 -1	1,02
RSV61-08	24,0	5	8,0	3,7	16	0,4	100	1,54

MATERIAL : A286 iaw W1.4944.4
 PASSIVATION : iaw ASTM A 380-96;

QUALITY ASSURANCE : EN2000

References:

JN0482

**WASHER, 100° DIMPLED, H.T.CRES ,
 PASSIVATED**

RSV61

ISSUE A

P:\PROVV\CATALOGO\RONDELLE\RSV61.DOC