

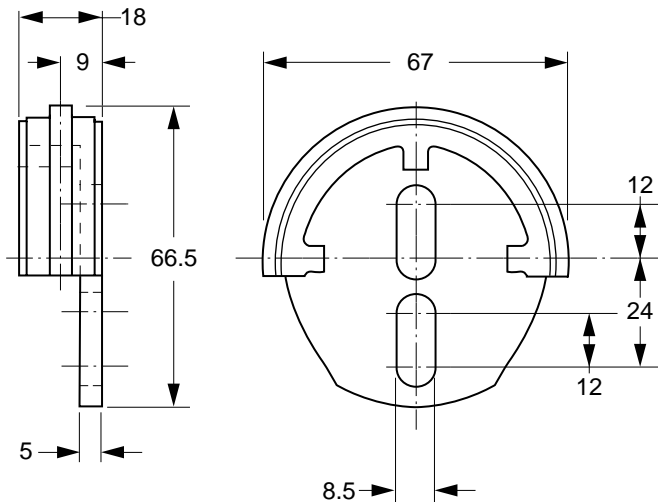

GA Type Tensioner

For 3/8" to 5/8" Pitch Roller Chains



MATERIAL: Body – Die-Cast Aluminum
Head – Low-Friction Special Wear-Resistant Polyethylene (UHMW-PE)
(Dynamic Coefficient: 0.06 on Dry Steel)
MAX. OPERATING TEMPERATURE: 65°C (149°F)

Catalog Number	Chain Pitch
QCT-GA03	3/8" x 7/32"
QCT-GA04	1/2" x 5/16"
QCT-GA05	5/8" x 3/8"
QCT-GA06	3/4" x 7/16"

All dimensions are in mm unless otherwise noted.

QTC, Econobelt & Zetasassi products are available from: **MARYLAND METRICS**
P.O.Box 261 Owings Mills, MD 21117 USA E-mail: sales@mdmetric.com
phones: (410)358-3130 (800)638-1830 faxes: (410)358-3142 (800)872-9329 url: <http://mdmetric.com>
copyright 2003 maryland metrics/qtc/econobelt/zetasassi