

Medium Voltage Fuses

European Standard

For Installation Inside
Transformers Under Oil



General purpose fuses installed in transformers

The installation of high-voltage fuse-links inside oil filled transformers provides space and cost savings in the total concept of distribution transformer substations. Furthermore they provide superior protection inside the so called “Intrinsically Safe Transformers”.

For this purpose, the high voltage fuses are designed as general purpose fuse-links. The fuse-links will provide detection and cut-off of a widest possible range of fault currents.

As well as the desired protection of transformer tanks against bursting, they also interrupt.

The fuse-links fulfill all requirements regarding oiltightness during the manufacturing phase of the transformer itself and also during service operation. The fuse-links are safe up to continuous temperatures of 105°C and can withstand very high temperatures arising during vacuum impregnation of transformers.

The fuse-links are provided with threaded holes size M10 at their contact caps for easy installation inside the transformer.

The fuse is age resistant, owing to the specific design of the fuse element and the use of high grade ceramic as well as appropriate sealing methods. These fuse-links can be used inside oil filled transformers free of any ageing for many decades.

Because these fuses are fitted inside transformers under oil, they are subjected to severe stresses, like partial discharges, high temperatures and vacuum during filling and drying process of transformer during manufacture. Superior design and construction of our fuses and long positive field experience eliminate problems, which may be caused due to such stresses.

Summary of Advantages

- ▷ Space and cost saving in distribution transformer substation design
- ▷ Protection against short-circuit and internal transformer faults
- ▷ Protection against bursting of the transformer through specific characteristic of the fuse-link
- ▷ Resistance against ageing



Medium Voltage Fuses
European Standard

**For Installation Inside
Transformers under Oil**

Selection Guide

Rated Voltage AC [kV]	Class	Part No.	Selector Guide [Page]	Techn. Data [Page]
12	General-purpose	30 310 91	HHO 3	HHO 5
12	Back-up	30 310 11	HHO 3	HHO 5
17.5	General-purpose	30 311 91	HHO 3	HHO 5
24	General-purpose	30 312 91	HHO 4	HHO 6
24	Back-up	30 312 11	HHO 4	HHO 6
36	Back-up	30 323 11	HHO 4	HHO 6



Medium Voltage Fuses
European Standard

For Installation Inside
Transformers under Oil

Rated Voltage
AC 12 kV **Oiltight**

Rated Current [A]	Part No.	Rated Breaking Current [kA]	Class	Weight [kg/1]	Pack
8	30 310 91.8	63	General-purpose	2.4	1
12	30 310 91.12	63	General-purpose	2.4	1
16	30 310 91.16	63	General-purpose	2.4	1
20	30 310 91.20	63	General-purpose	2.4	1
22	30 310 91.22	63	General-purpose	2.4	1
40	30 310 91.40	63	General-purpose	2.4	1
50	30 310 91.50	63	General-purpose	2.4	1
63	30 310 91.63	63	General-purpose	2.4	1
80	30 310 11.80	63	Back-up	2.4	1
100	30 310 11.100	63	Back-up	2.4	1
125	30 310 11.125	63	Back-up	2.4	1

Rated Voltage
AC 17.5 kV **Oiltight**

Rated Current [A]	Part No.	Rated Breaking Current [kA]	Class	Weight [kg/1]	Pack
8	30 311 91.8	63	General-purpose	2.4	1
10	30 311 91.10	63	General-purpose	2.4	1
12	30 311 91.12	63	General-purpose	2.4	1
16	30 311 91.16	63	General-purpose	2.4	1
20	30 311 91.20	63	General-purpose	2.4	1

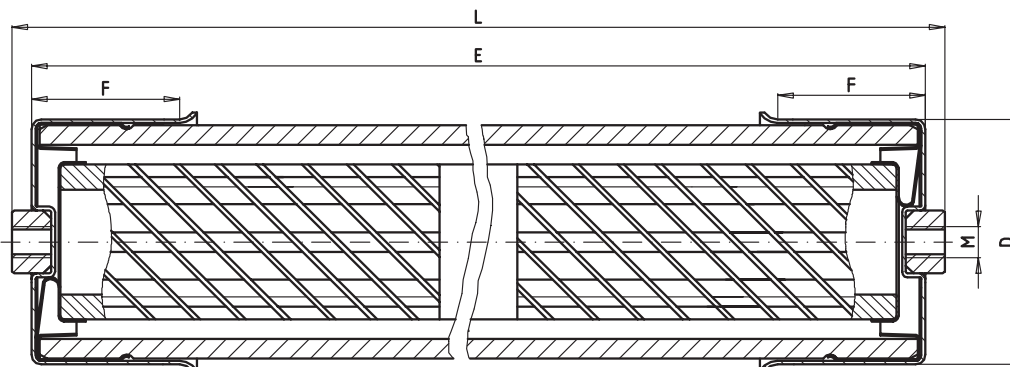

D	2.48" (63.5 mm)
E	14.17" (360 mm)
F	1.57" (40 mm)
L	14.60" (371 mm)
M	M8



Medium Voltage Fuses European Standard

For Installation Inside
Transformers under Oil

Rated Voltage
AC 24 kV

Oiltight

Rated Current [A]	Part No.	Rated Breaking Current [kA]	Class	Weight [kg/1]	Pack
8	30 312 91.8	63	General-purpose	2.4	1
12	30 312 91.12	63	General-purpose	2.4	1
16	30 312 91.16	63	General-purpose	2.4	1
20	30 312 91.20	63	General-purpose	2.4	1
31.5	30 312 11.31.5	63	Back-up	2.4	1
40	30 312 11.40	63	Back-up	2.4	1
50	30 312 11.50	63	Back-up	2.4	1
63	30 312 11.63	63	Back-up	2.4	1
80	30 312 11.80	63	Back-up	2.4	1

Rated Voltage
AC 36 kV

Oiltight

Rated Current [A]	Part No.	Rated Breaking Current [kA]	Class	Weight [kg/1]	Pack
10	30 323 11.10	40	Back-up	2.4	1
16	30 223 11.16	40	Back-up	2.4	1
20	30 323 11.20	40	Back-up	2.4	1
25	30 323 11.25	40	Back-up	2.4	1
31.5*	30 324 11.31.5	40	Back-up	2.4	1
40*	30 324 11.40	40	Back-up	2.4	1

* E= 17.32 " (440 mm)

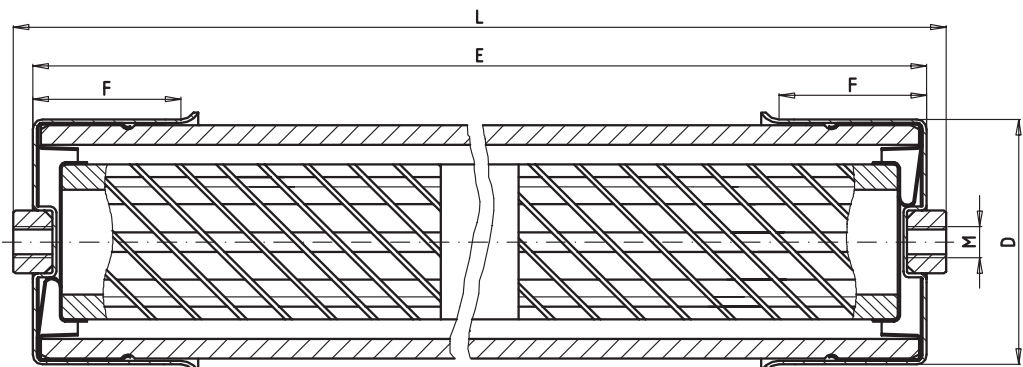

D	2.48" (63.5 mm)
E	14.17" (360 mm)
F	1.57" (40 mm)
L	14.60" (371 mm)
M	M8

Length

360 mm

Rated Voltage

AC 12 kV

Class

General-Purpose / Back-up

Rated Current [A]	Part No.	Rated Breaking Current [kA]	Power Loss [W]	Class	Pre-arcing I ² t-value [A ² s]	Total I ² t-value [A ² s]
8	30 310 91.8	63	8	General-purpose	172	1 800
12	30 310 91.12	63	13	General-purpose	340	3 800
16	30 310 91.16	63	16.5	General-purpose	830	9 200
20	30 310 91.20	63	20	General-purpose	1 730	17 300
22	30 310 91.22	63	12	General-purpose	2 260	22 600
40	30 310 91.40	63	35	General-purpose	3 530	35 500
50	30 310 91.50	63	46	General-purpose	5 490	55 000
63	30 310 91.63	63	62	General-purpose	9 030	90 000
80	30 310 11.80	63	91	Back-up	17 500	175 000
100	30 310 11.100	63	115	Back-up	41 500	415 000
125	30 310 11.125	63	176	Back-up	56 500	565 000

Length

360 mm

Rated Voltage

AC 17.5 kV

Class

General-Purpose

Rated Current [A]	Part No.	Rated Breaking Current [kA]	Power Loss [W]	Class	Pre-arcing I ² t-value [A ² s]	Total I ² t-value [A ² s]
8	30 311 91.8	63	10	General-purpose	172	1 800
10	30 311 91.10	63	15	General-purpose	250	2 800
12	30 311 91.12	63	17	General-purpose	460	5 100
16	30 311 91.16	63	22	General-purpose	1 100	12 000
20	30 311 91.20	63	27	General-purpose	1 700	18 500

**Time-current characteristics and cut-off current diagram
please refer to pages HHO 7 and HHO 8**

Length **360 mm** Rated Voltage **AC 24 kV** Class **General-Purpose / Back-up**

Rated Current [A]	Part No.	Rated Breaking Current [kA]	Power Loss [W]	Class	Pre-arcing I ² t-value [A ² s]	Total I ² t-value [A ² s]
8	30 312 91.8	63	17	General-purpose	172	1 900
10	30 312 91.10	63	21	General-purpose	250	2 800
12	30 312 91.12	63	24	General-purpose	460	5 100
16	30 312 91.16	63	31	General-purpose	830	8 300
20	30 312 91.20	63	21	General-purpose	1 730	17 300
31.5	30 312 11.31.5	63	76	Back-up	1 400	14 000
40	30 312 11.40	63	94	Back-up	2 200	22 000
50	30 312 11.50	63	108	Back-up	4 700	47 000
63	30 312 11.63	63	114	Back-up	8 700	87 000
80	30 312 11.80	63	176	Back-up	13 500	135 000

Length **360 mm** Rated Voltage **AC 36 kV** Class **Back-up**

Rated Current [A]	Part No.	Rated Breaking Current [kA]	Power Loss [W]	Class	Pre-arcing I ² t-value [A ² s]	Total I ² t-value [A ² s]
10	30 323 11.10	40	85	Back-up	70	1 100
16	30 323 11.16	40	50	Back-up	160	1 900
20	30 323 11.20	40	73	Back-up	550	6 600
25	30 323 11.25	40	88	Back-up	920	11 000
31.5	30 324 11.31.5	40	132	Back-up	1 400	16 800
40	30 324 11.40	40	152	Back-up	2 640	31 700

**TIME/CURRENT CHARACTERISTICS AND CUT-OFF CURRENT DIAGRAM
PLEASE REFER TO PAGES HHO 7 AND HHO 8**

Time-Current Characteristics **Back-up**

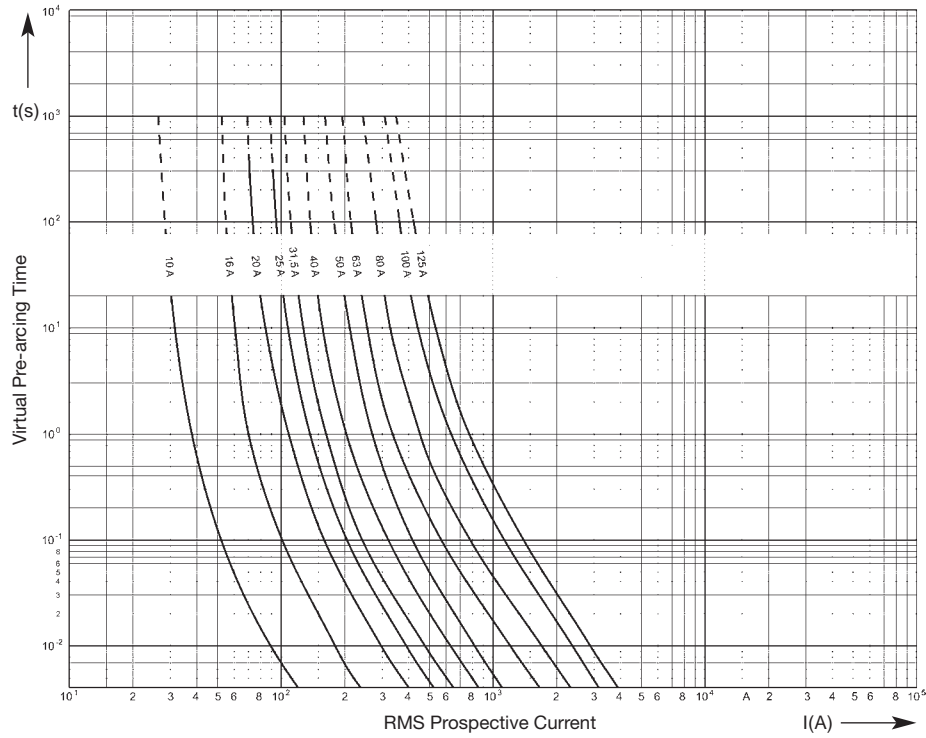

Cut-Off Current Diagram **Back-up**

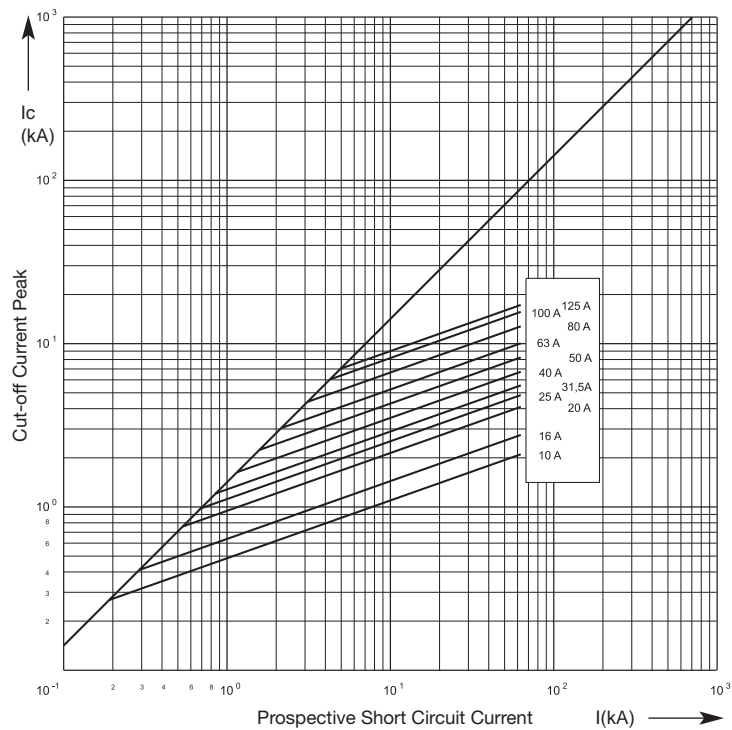

Time-Current Characteristics **General-Purpose**

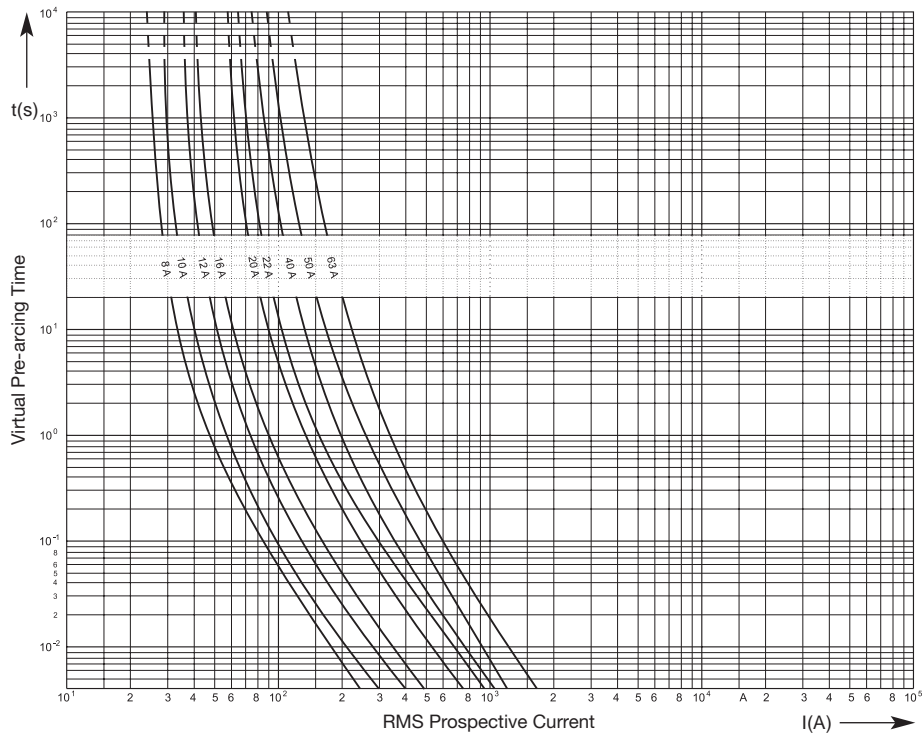

Cut-Off Current Diagram **General-Purpose**

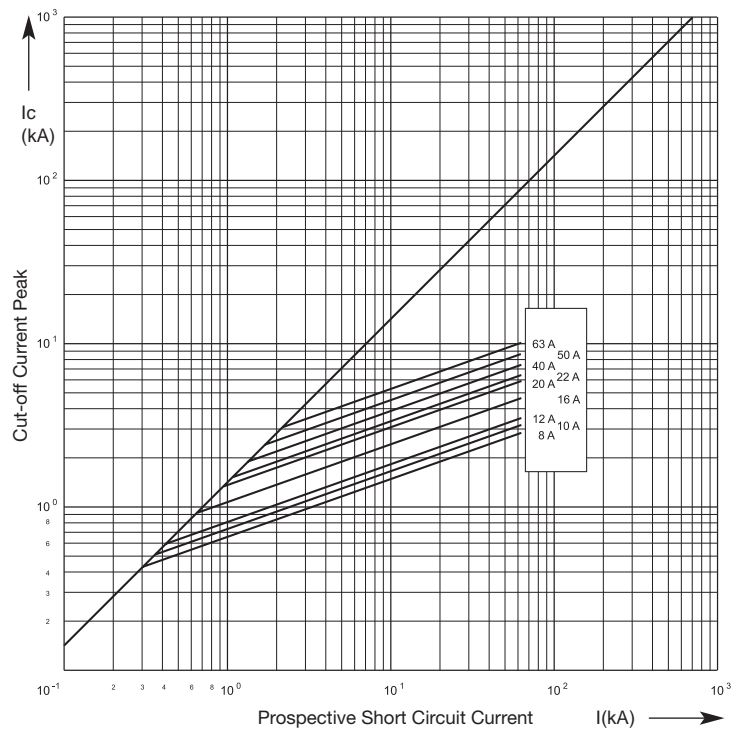

Recommendation for Protection of Main Transformer

Rated Voltage [kV]	Transformer Rated Capacity [kVA]										
	50	100	160	200	250	315	400	500	630	800	1000
12	8	12	16	20	22	40	50	63	80	100	-
24	8	8	10	12	16	20	20	31.5	40	63	80
36	-	-	10	16	16	20	20	-	-	-	-



