

Flange filettate a collare UNI 2253-67 PN 6 e UNI 2254-67 PN 16

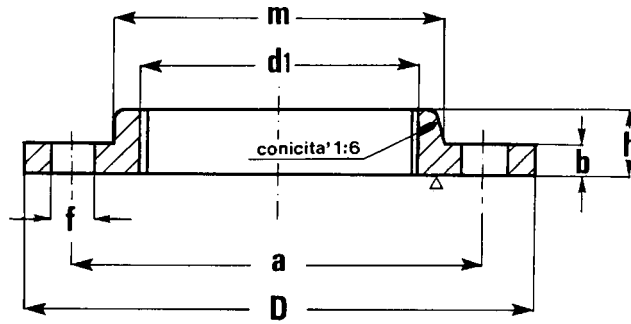

DN	DN	a	D	b	d1	f	h	m	VITI	N. FORI	Kg.
----	----	---	---	---	----	---	---	---	------	---------	-----

UNI 2253-67 PN 6

3/8"	10	50	75	12	3/8"	11	20	25	M10	4	0,390
1/2"	15	55	80	12	1/2"	11	20	30	M10	4	0,430
3/4"	20	65	90	14	3/4"	11	24	40	M10	4	0,660
1"	25	75	100	14	1"	11	24	50	M10	4	0,820
1 1/4"	32	90	120	14	1 1/4"	14	26	60	M12	4	1,170
1 1/2"	40	100	130	14	1 1/2"	14	26	70	M12	4	1,400
2"	50	110	140	14	2"	14	28	80	M12	4	1,590
2 1/2"	65	130	160	14	2 1/2"	14	32	100	M12	4	2,170
3"	80	150	190	16	3"	18	34	110	M16	4	3,200
4"	100	170	210	16	4"	18	38	130	M16	4	3,590
5"	125	200	240	18	5"	18	40	160	M16	8	4,940
6"	150	225	265	18	6"	18	44	185	M16	8	5,830

UNI 2254-67 PN 16

3/8"	10	60	90	14	3/8"	14	20	30	M12	4	0,630
1/2"	15	65	95	14	1/2"	14	20	35	M12	4	0,700
3/4"	20	75	105	16	3/4"	14	24	45	M12	4	1,010
1"	25	85	115	16	1"	14	24	52	M12	4	1,210
1 1/4"	32	100	140	16	1 1/4"	18	26	60	M16	4	1,760
1 1/2"	40	110	150	16	1 1/2"	18	26	70	M16	4	2,040
2"	50	125	165	18	2"	18	28	85	M16	4	2,850
2 1/2"	65	145	185	18	2 1/2"	18	32	105	M16	4	3,530
3"	80	160	200	20	3"	18	34	118	M16	8	4,240
4"	100	180	220	20	4"	18	38	140	M16	8	4,900
5"	125	210	250	22	5"	18	40	168	M16	8	6,630
6"	150	240	285	22	6"	22	44	195	M20	8	8,490