

DIN 86029

Hubbed slip-on flanges for welding: nominal pressure 10

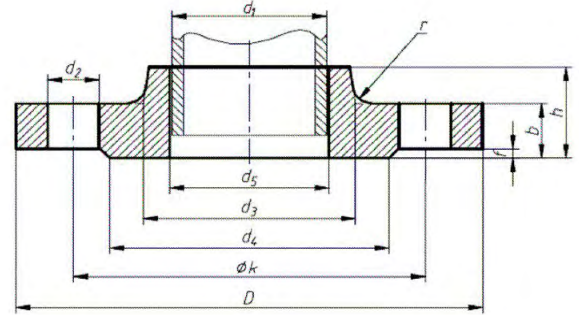

measurements in mm

Nominal size DN	pipe OD d ₁	flange					neck		gasket width d ₄	face height f	screws			weight (7.85 kg/dm ³) kg
		D	d ₅	b	k	h	d ₃	r			number	thread	d ₂	
For nominal sizes DN 10-175 use DIN 86030 Nominal pressure 16														
200	219,1	340	222	24	295	44	247	6	268	3	8	M 20	22	9,9
250	273	395	276	26	350	46	300	6	320	3	12	M 20	22	12,7
300	323,9	445	327	26	400	46	352	6	370	4	12	M 20	22	14,4
350	355,6	505	359	26	460	53	398	10	430	4	16	M20	22	22,3
400	406,4	565	410	26	515	57	448	10	482	4	16	M24	26	26,7
(450)	457	615	461	28	565	62	502	10	532	4	20	M24	26	32,3
500	508	670	512	28	620	67	552	10	585	4	20	M24	26	37,3
600	610	780	614	28	725	75	658	10	685	5	20	M27	30	48,3
700	711	895	716	30	840	77	760	10	800	5	24	M27	30	62,7
800	813	1015	818	32	950	84	864	10	905	5	24	M30	33	83,4
900	914	1115	920	34	1050	88	969	10	1005	5	28	M30	33	99,2
1000	1016	1230	1022	34	1160	92	1071	10	1110	5	28	M33	36	116,8

Do not use Nominal sizes in parentheses wherever possible.

Tolerances table 2

Nominal size DN	D	d ₅	b	k	h	d ₄	d ₂	d ₃	r	f
200 and 250	± 1	+1	± 1,5	± 1,6	± 3	0	+ 0,50	DIN 7168-g		
300	± 3					-2	0			
350		0	0	0						
400	+ 1,5	-3	+1							
450 and 500	0	0	0							
600	± 5	+3 / 0	DIN 7168-g							
700 to 1000										

DIN 86030

Hubbed slip-on flanges for welding: nominal pressure 16

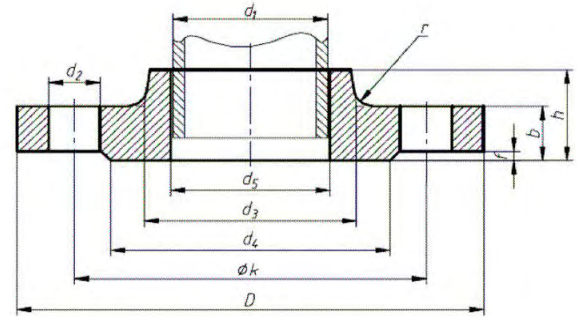

measurements in mm

Nominal size DN	pipe OD d ₁	flange					neck		gasket width d ₄	face height f	screws			weight (7.85 kg/dm ³) kg
		D	d ₅	b	k	h	d ₃	r			number	thread	d ₂	
10	17.2	90	17.7	14	60	20	30	4	40	2	4	M 12	14	0.56
15	21.3	95	22	14	65	20	35	4	45	2	4	M 12	14	0.62
20	26.9	105	27.6	16	75	24	45	4	58	2	4	M 12	14	0.91
25	33.7	115	34.4	16	85	24	52	5	68	2	4	M 12	14	1.09
32	42.4	140	43.1	16	100	26	60	5	78	2	4	M 16	18	1.58
40	48.3	150	49	16	110	26	70	5	88	3	4	M 16	18	1.76
50	60.3	165	61.1	18	125	28	85	5	102	3	4	M 16	18	2.39
65	76.1	185	77.1	18	145	32	105	5	122	3	4	M 16	18	3.1
80	88.9	200	90.3	20	160	34	118	5	138	3	8	M 16	18	3.77
100	114.3	220	115.9	20	180	38	140	5	158	3	8	M 16	18	4.29
125	139.7	250	141.6	22	210	40	168	5	188	3	8	M 16	18	5.86
150	168.3	285	170.5	22	240	44	196	5	212	3	8	M 20	22	7.22
175	193.7	315	196.1	24	270	44	224	6	242	3	8	M 20	22	9.18

measurements in mm

Nominal size DN	pipe OD d ₁	flange					neck		gasket width d ₄	face height f	screws			weight (7.85 kg/dm ³) kg
		D	d ₅	b	k	h	d ₃	r			number	thread	d ₂	
200	219.1	340	222	24	295	44	247	6	268	3	12	M20	22	9.7
250	273	405	276	26	355	46	300	6	320	3	12	M24	26	13.4
300	323.9	460	327	28	410	46	355	6	378	4	12	M24	26	17.3
350	355.6	520	359	30	470	57	400	10	438	4	16	M24	26	27.6
400	406.4	580	410	32	525	63	457	10	490	4	16	M27	30	36.0
450	457	640	461	34	585	68	505	10	550	4	20	M27	30	44.0
500	508	715	512	34	650	73	559	10	610	4	20	M30	33	56.4
600	610	840	614	36	770	83	664	10	725	5	20	M33	36	79.9
700	711	910	716	36	840	83	760	10	795	5	24	M33	36	75.7
800	813	1025	818	38	950	90	864	10	900	5	24	M36	39	97.6
900	914	1125	920	40	1050	94	969	10	1000	5	28	M36	39	114.6
1000	1016	1255	1022	42	1170	100	1073	10	1115	5	28	M39	42	151.2

Tolerances table 2

Nominal size DN	D	d ₅	b	k	h	d ₄	d ₂	d ₃	r	f
10 to 80 100	± 1	+ 0,50 0	± 1,3	± 1,6	± 1,5	0/-1	+ 0,50 0	DIN 7168-g		
125 to 200 250 300		+1 0	± 1,5		± 2	0 - 2	+1 0			
350 and 400 450 and 500	± 3	+ 1,5 0		± 3	0 - 3					
600 700 to 1000	± 5	+3 / 0	DIN 7168-g							