

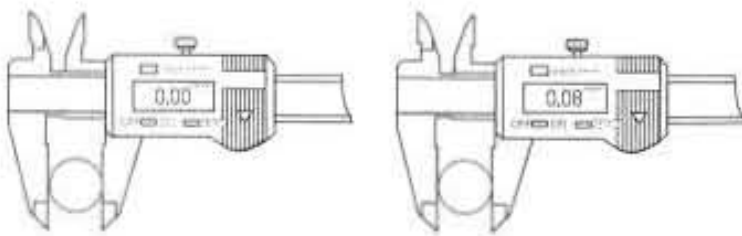

ELECTRONIC DIGITAL CALIPER

OPERATING INSTRUCTIONS

E. Differential method of measurement
(Application of zero setting)



● MAINTENANCE INSTRUCTIONS

1. Clean caliper bar with dry cotton fabrics before using in order to avoid bad display of caliper caused by humidity.
2. Keep the caliper clean and dry (Liquid can damage the slider).
3. Faces should be cleaned gently with cotton fabrics. Never use petrol, acetone and other organic solutions.
4. In order to save power, turn off the unit when caliper is going to stay idle for some time.
5. Never apply any electric pressure on any part of the caliper and never use an electric pen for the fear of damaging its chip.
6. For other notes please refer to the conventional calipers.
7. Accidental wrong display may happen while replacing the battery. just take out the battery and then put it in again after more than 30 seconds until the display returns to normal.

● BATTERY REPLACEMENT

Flashing of digits shows a flat battery. Take off the battery cover in the direction shown by the arrow and replace the battery (positive side facing out).

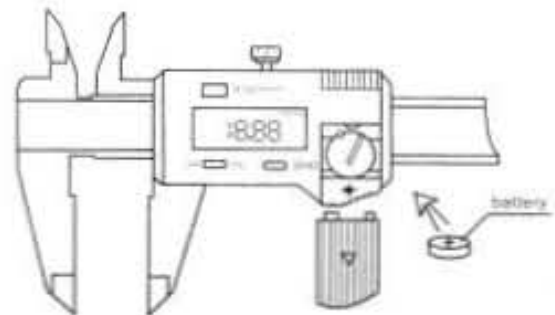

● TROUBLE SHOOTING

Failure	Cause	Measure
Five digits flash simultaneously, about once per sec.	Battery voltage lower than 1.45V.	Replace the battery.
Display doesn't change when the slider is moved	Accidental trouble in circuit	Take out battery and reset it after 30 sec.
Less accurate than specified but within $\pm 0.1\text{mm}$	Dirt in the sensor.	Remove slider cover and its assembly, clean face of sensor with clean compressed air (5kg/cm^2).
No display on LCD	1. Battery in poor contact. 2. Battery voltage under 1.4V.	1. Remove battery cover and adjust the battery seat, keep good connection. 2. Replace battery.

● TECHNICAL SPECIFICATIONS

Measuring range: 0-75mm / 0-3", 0-100mm / 0-4",
0-150mm / 0-6", 0-200mm / 0-8",
0-300mm / 0-12".
Resolution: 0.01mm / 0.0005"
Accuracy: $\pm 0.02\text{mm} / 0.001"$ (<100mm)
 $\pm 0.03\text{mm} / 0.001"$ (>100-200mm)
 $\pm 0.04\text{mm} / 0.0015"$ (>200-300mm)
Repeatability: 0.01mm / 0.0005"
Max. measuring speed: 1.5m / sec, 60" / sec.
Measuring system: Linear capacitive measuring system.
Display: LCD display.
Power: One 1.55V button cell.

capacity: 165mAh

Working temperature: 5°C-40°C / 41 to 104 degrees F.

Influence of humidity: Not important under 80% of relative humidity.

● NOMENCLATURE

- | | |
|-------------------------------------|----------------------------|
| 1. Internal measuring jaws | 2. METRIC/INCH change over |
| 3. Locking screw | 4. LCD display |
| 5. External measuring jaws | 6. Power off button |
| 7. Zero setting and power on button | 8. Battery cover |
| 9. Depth measuring blade | 10. Step-measuring faces |

1. PREPARATIONS:

- (1) Slider can be removed only after the locking screw (No.3 item of the Nomenclature) is loosened.
- (2) Wipe clean all the measuring faces and caliper bar. No organic solutions are allowed.
- (3) Check to see if all the buttons, switches, and LCD display respond well.

2. Basic measuring methods:

- (1) Loosen the locking screw.
- (2) Switch the unit on with a press on "ON" button. Then select the unit system needed by pressing Inch/Metric button. (Each time the button is pressed, inch and metric digits will be displayed alternatively).

- (3) Apply normal measuring pressure on slider to close the external measuring jaws. Then press "zero" button to reset the display to zero.

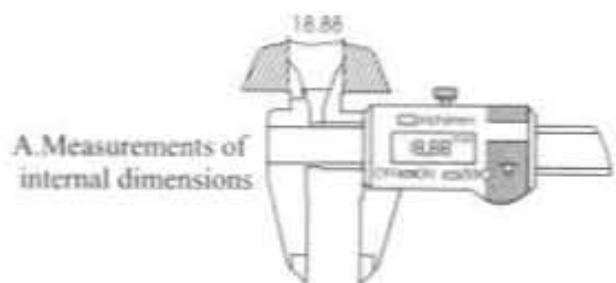

A. Measurements of internal dimensions

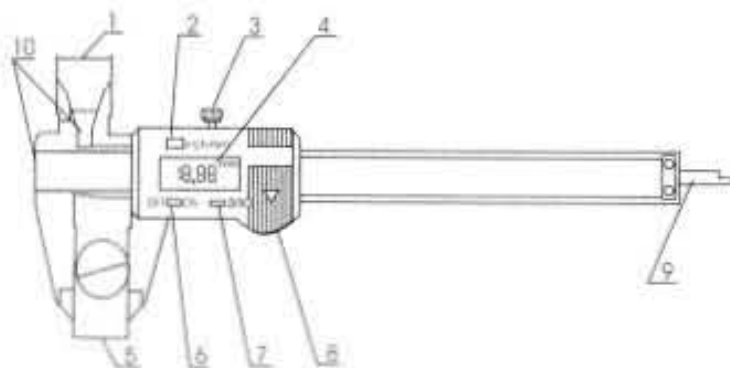

B. Measurements of external dimensions

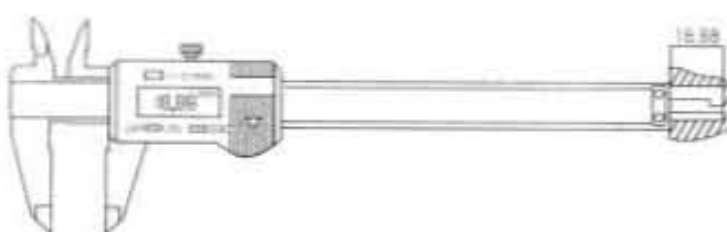

C. Measurements of depth

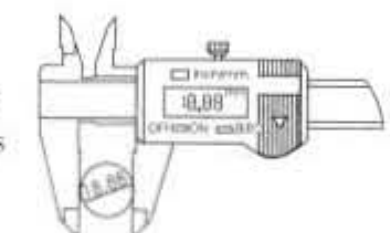

D. Measurement of steps