

TUBTARA® PRODUCTS ARE AVAILABLE AT:

MARYLAND METRICS

P.O. Box 261
 phones: (410)358-3130
 faxes: (410)358-3142
 URL: <http://mdmetric.com>

Owings Mills, MD 21117 USA
 (800)638-1830
 (800)872-9329
 E-mail: sales@mdmetric.com

DFS 109 TH

Hand tool for punching hexagonal holes

This special heavy duty hand tool allows you to convert round holes into hexagon.

CAPACITY

hexagonal holes for blind nuts and bolts from M4 to M10.

Tubtara	Maximum sheet thickness	
	Alu*, Steel**, Brass**	Stainless Steel
M4	2 mm	1,0 mm
M5	3 mm	1,5 mm
M6	3 mm	1,5 mm
M8	3 mm	1,5 mm
M10	3 mm	1,5 mm
M5	5 mm in Alu	/
M6	6 mm in Alu	/
M8	6 mm in Alu	/

*until F 27 max. **until St. 40 max.

CHARACTERISTICS

Unbreakable steel reinforced tool body.
 The DFS 109 TH hand tool is supplied in a wooden box.

PUNCHING METHOD

1. Pre-drill the exact hole diameter (**see operating instructions**).
2. Put the punch into the hole of the work piece.
3. By pushing the center pin inwards, the punch is pushed apart and grips the material behind the workpiece.
4. By closing the handles completely, the punch is pulled back leaving a clean hexagonal hole.

TECHNICAL FEATURES

Weight : 2,2 kg
Length : 55 cm
Width (with closed handles) : 16 cm
Width (with open handles) : 45 cm
Stroke : 7,2 mm
Total weight (with box) : 3,5 kg

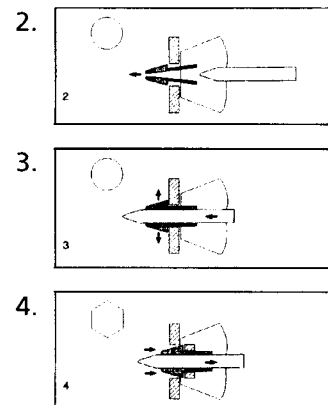
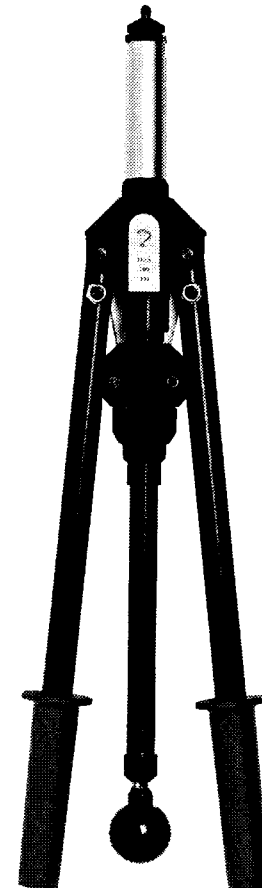
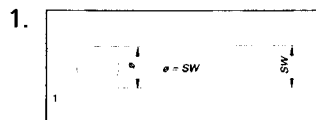

EQUIPMENT

Basic tool equipped in one size (to be specified).
 Instruction manual with spare parts list.