

MARYLAND METRICS THREAD DATA CHARTS

DIN 158

PIPE THREAD -- METRIC TAPER PIPE -- MT

Example Designation: DIN 158 - M 30 x 2 keg

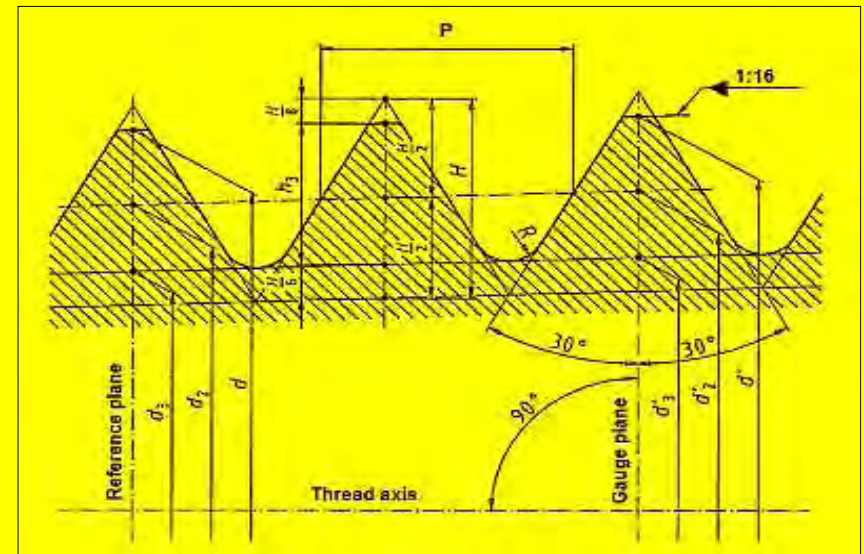
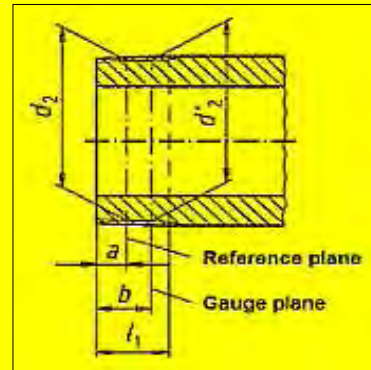

Type of thread: female thread cylindrical (M-thread acc. DIN 13)
male thread thread conical (taper 1:16)

Limits of size for taper external threads at gauge plane

Thread size	Standard design						Short design					
	Major diameter, d'		Pitch diameter, d'2		Minor diameter, d'3		Major diameter, d'		Pitch diameter, d'2		Minor diameter, d'3	
	Maximum	Minimum	Maximum	Minimum	Maximum	Minimum	Maximum	Minimum	Maximum	Minimum	Maximum	Minimum
M 5 keg	5,08	5,02	4,56	4,5	4,099	4,039	-	-	-	-	-	-
M 6 keg	6,108	6,018	5,458	5,368	4,881	4,791	6,093	6,033	5,443	5,383	4,866	4,806
M 8 x 1 keg	8,108	8,018	7,458	7,368	6,881	6,791	8,093	8,033	7,443	7,383	6,866	6,806
M 10 x 1 keg	10,108	10,018	9,458	9,368	8,881	8,791	10,093	10,033	9,443	9,383	8,866	8,806
M 12 x 1 keg	12,108	12,018	11,458	11,368	10,881	10,791	12,093	12,033	11,443	11,383	10,866	10,806
M 10 x 1,25 keg	10,181	10,069	9,369	9,257	8,647	8,535	10,165	10,085	9,353	9,273	8,631	8,551
M 12 x 1,25 keg	12,181	12,069	11,369	11,257	10,647	10,535	12,165	12,085	11,353	11,273	10,631	10,551
M 12 x 1,5 keg	12,251	12,125	11,277	11,151	10,411	10,285	12,235	12,141	11,261	11,167	10,395	10,301
M 14 x 1,5 keg	14,251	14,125	13,277	13,151	12,411	12,285	14,235	14,141	13,261	13,167	12,395	12,301
M 16 x 1,5 keg	16,251	16,125	15,277	15,151	14,411	14,285	16,235	16,141	15,261	15,167	14,395	14,301
M 18 x 1,5 keg	18,251	18,125	17,277	17,151	16,411	16,285	18,235	18,141	17,261	17,167	16,395	16,301
M 20 x 1,5 keg	20,251	20,125	19,277	19,151	18,411	18,285	20,235	20,141	19,261	19,167	18,395	18,301
M 22 x 1,5 keg	22,251	22,125	21,277	21,151	20,411	20,285	22,235	22,141	21,261	21,167	20,395	20,301
M 24 x 1,5 keg	24,251	24,125	23,277	23,151	22,411	22,285	24,235	24,141	23,261	23,167	22,395	22,301
M 26 x 1,5 keg	26,251	26,125	25,277	25,151	24,411	24,285	26,235	26,141	25,261	25,167	24,395	24,301
M 27 x 1,5 keg	27,251	27,125	26,277	26,151	25,411	25,285	27,235	27,141	26,261	26,167	25,395	25,301
M 30 x 1,5 keg	30,251	30,125	29,277	29,151	28,411	28,285	30,235	30,141	29,261	29,167	28,395	28,301

Thread size	Standard design						Short design					
	Major diameter, d´		Pitch diameter, d´2		Minor diameter, d´3		Major diameter, d´		Pitch diameter, d´2		Minor diameter, d´3	
	Maximum	Minimum	Maximum	Minimum	Maximum	Minimum	Maximum	Minimum	Maximum	Minimum	Maximum	Minimum
M 33 x 1,5 keg	33,313	33,125	32,339	32 ,151	31,473	31,285	33,282	33,156	32,308	32 ,182	31,442	31,316
M 36 x 1,5 keg	36,313	36,125	35,339	35,151	34,473	34,285	36,282	36,156	35,308	35,182	34,442	34,316
M 38 x 1,5 keg	38,313	38,125	37,339	37,151	36,473	36,285	38,282	38,156	37,308	37,182	36,442	36,316
M 39 x 1,5 keg	39,313	39,125	38,339	38,151	37,473	37,285	39,282	39,156	38,308	38,182	37,442	37,316
M 42 x 1,5 keg	42,313	42,125	41,339	41 ,151	40,473	40,285	42,282	42,156	41,308	41,182	40,442	40,316
M 45 x 1,5 keg	45,313	45,125	44,339	44,151	43,473	43,285	45,282	45,156	44,308	44,182	43,442	43,316
M 48 x 1,5 keg	48,313	48,125	47,339	47,151	46,473	46,285	48,282	48,156	47,308	47,182	46,442	46,316
M 52 x 1,5 keg	52,313	52,125	51 ,339	51 ,151	50,473	50,285	52,282	52,156	51,308	51,182	50,442	50,316
M 27 x 2 keg	27,344	27,156	26,045	25,857	24,89	24,702	27,313	27,187	26,014	25,888	24,859	24,733
M 30 x 2 keg	30,344	30,156	29,045	28,857	27,89	27,702	30,313	30,187	29,014	28,888	27,859	27,733
M 33 x 2 keg	33,344	33,156	32,045	31 ,857	30,89	30,702	33,313	33,187	32 ,014	31 ,888	30,859	30,733
M 36 x 2 keg	36,365	36,135	35,066	34,836	33,911	33,681	36,325	36,175	35,026	34,876	33,871	33,721
M 39 x 2 keg	39,365	39,135	38,066	37,836	36,911	36,681	39,325	39,175	38,026	37,876	36,871	36,721
M 42 x 2 keg	42,365	42,135	41 ,066	40,836	39,911	39,681	42,325	42,175	41 ,026	40,876	39,871	39,721
M 45 x 2 keg	45,365	45,135	44,066	43,836	42,911	42,681	45,325	45,175	44,026	43,876	42,871	42,721
M 48 x 2 keg	48,365	48,135	47,066	46,836	45,911	45,681	48,325	48,175	47,026	46,876	45,871	45,721
M 52 x 2 keg	52,365	52,135	51,066	50,836	49,911	49,681	52,325	52,175	51,026	50,876	49,871	49,721
M 56 x 2 keg	56,365	56,135	55 ,066	54,836	53 ,911	53,681	56,325	56,175	55,026	54,876	53,871	53,721
M 60 x 2 keg	60,365	60,135	59,066	58,836	57,911	57,681	60,325	60,175	59,026	58,876	57,871	57,721

Nominal sizes for taper external threads

Thread size	Pitch, P	Useful thread length, l1		Maximum height of thread, h3		Dimensions at reference plane				Dimensions at gauge plane					
		Standard design	Short design	Standard design	Short design	Dimension a		Thread dimensions at gauge plane			Gauge length b		Thread dimensions		
						Standard design	Short design	Major diameter, d	Pitch diameter, d'2	Minor diameter, d'3	Standard design	Short design	d'	d'2	d'3
M5 keg	0,8	5	-	0,521	-	2	-	5	4,48	4,019	2,8	-	5,05	4,53	4,069
M6 keg	1	5,5	4	0,659	0,644	2,5	2	6	5,35	4,773	3,5	3	6,063	5,413	4,836
M8 x 1 keg								8	7,35	6,773			8,063	7,413	6,836
M10 x 1 keg								10	9,35	8,773			10,063	9,413	8,836
M12 x 1 keg								12	11,35	10,773			12,063	11,413	10,836
M10x 1,25 keg	1,25	7	6	0,823	0,807	3	2,2	10	9,188	8,466	5	4,2	10,125	9,313	8,591
M12 x 1,25 keg								12	11,188	10,466			12,125	11,313	10,591
M12x 1,5 keg	1,5	8,5	7,5	0,983	0,967	3,5	2,5	12	11,026	10,16	6,5	5,5	12,188	11,214	10,348
M14 x 1,5 keg								14	13,026	12,16			14,188	13,214	12,348
M16 x 1,5 keg								16	15,026	14,16			16,188	15,214	14,348
M18 x 1,5 keg								18	17,026	16,16			18,188	17,214	16,348
M20 x 1,5 keg								20	19,026	18,16			20,188	19,214	18,348
M22 x 1,5 keg								22	21,026	20,16			22,188	21,214	20,348
M24 x 1,5 keg								24	23,026	22,16			24,188	23,214	22,348
M26 x 1,5 keg								26	25,026	24,16			26,188	25,214	24,348
(M27 x 1,5 keg)								27	26,026	25,16			27,188	26,214	25,348
M30 x 1,5 keg								30	29,026	28,16			30,188	29,214	28,348

copyright 2011 maryland metrics ver gg10c

Threads according to this norm are used for pipe connections with conical screw-in plugs or fittings size C, which are to screwed into cylindrical screw-in holes size Z, both according to DIN 3852 part 1. The distance a of the relating level corresponds to DIN 3852 part 1. The conical outside thread of this norm shows at the relating level point the same effective diameter as the relating cylindrical inner thread according DIN 13, so it can be manually screwed in until that relating level. The adjustment power created by using of a suitable tool increases the thread reach and seals the screw connection supported by a suitable sealant (e.g. hemp or Teflon). Outside, effective and core diameter show the same ± tolerance, the tabular form list shows averages only. The cylindrical inner thread according DIN 13 shows the tolerance - 4H5H, to keep the free space between the crest of thread and the leakage space as small as possible.

THINK!- MARYLAND METRICS - The One-Stop Source For Metric And British Sized Fasteners, Wrenches, Cutting, And Measuring Tools, Metal Shapes, Oil Seals, O-Rings, Mechanical Power Transmission Equipment, Bearings, Hydraulic And Pneumatic Fittings & Tubing, Workholding Components, Plumbing Fittings, & Some Electrical & Electronic Components.

[Click to go to Maryland Metrics home page](#)

Phones: (800) 638-1830 or (410) 358-3130 are available Monday-Friday 8:30 AM to 5:30 PM Eastern time.

Faxes: (800) 872-9329 or (410) 358-3142 & E-mail are available anytime.

Warehouse & showroom hours are Monday-Friday 10 AM to 5:30 PM.

[To: Maryland Metrics home page] [To: Maryland Metrics Product Guide] [e-mail to Maryland Metrics]

Please note that all Trademarks and Tradenames are the property of their respective owners.

copyright 2011 maryland metrics -- all rights reserved -- ver gg10c thddata22.htm